

E D E L B R O C K

PERFORMER SERIES[®] CARBURETOR

Owner's Manual

For these Performer Series Carburetors:

1403, 1404, 1405, 1406, 1407, 1409,
1410, 1411, 1412 and 1413

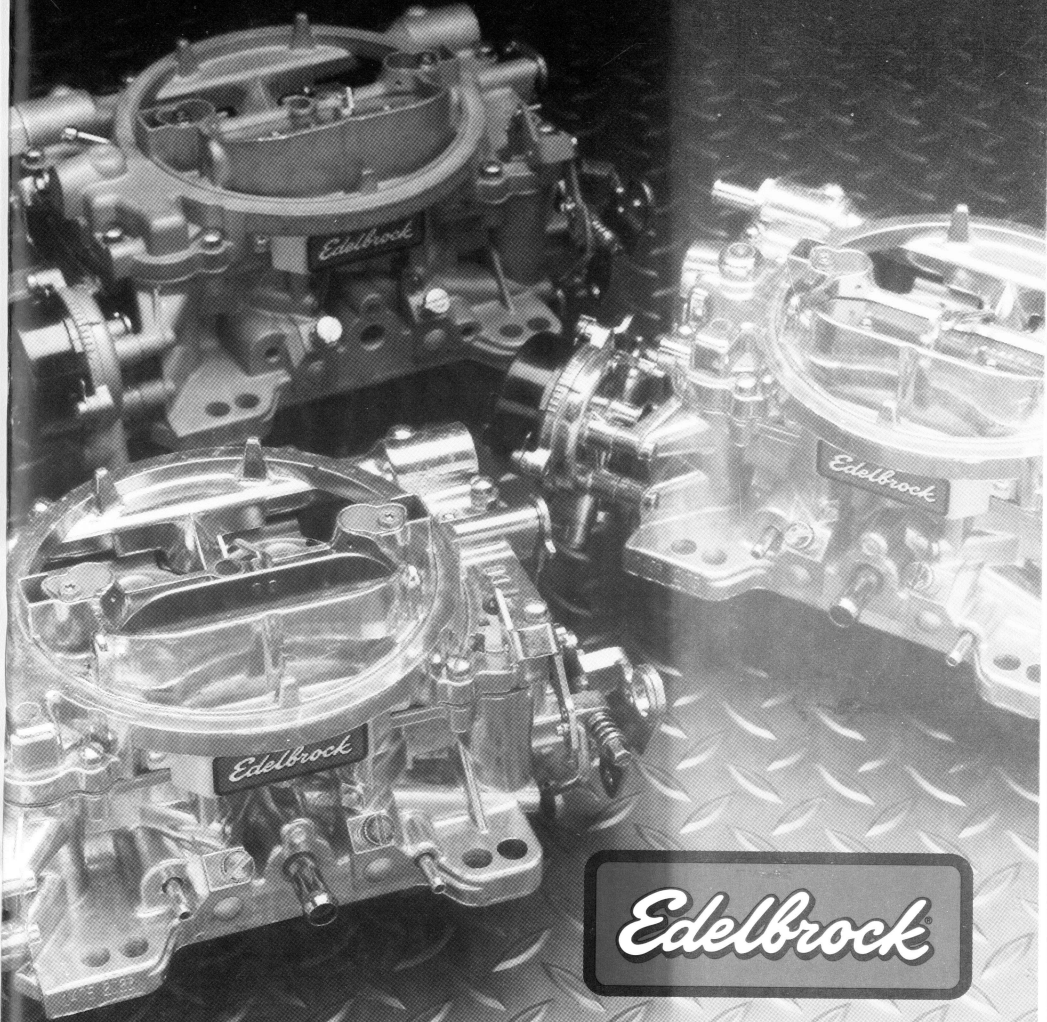

INTRODUCTION

Your Edelbrock Performer Series carburetor was calibrated using Edelbrock Performer, Performer RPM, and Torker II Power Packages. The carburetor metering was developed on Edelbrock engine dynamometers, chassis rolls, and a variety of development vehicles. Although in most applications you will not need to recalibrate your carburetor, you may wish to change the factory calibration to best meet any unique needs of your engine.

The following manual consists of 2 sections; Theory of Operation and Tuning Procedure. Upon review of Section 1, Theory of Operation, you will be prepared to develop your own individualized calibration. Section 2, Tuning Procedures will take you through a step-by-step procedure that will enable you to achieve a desirable calibration. For added ease of tuning, a Calibration Reference Chart for your model of carburetor has been included.

TABLE OF CONTENTS

SECTION 1:	THEORY OF OPERATION	2
	BASIC ENGINE REQUIREMENTS	2
	METERING SYSTEMS	3
	1. Idle System	3
	2. Primary Main System	4
	3. Secondary Main System	6
	TRANSIENT CONTROL SYSTEMS	6
	1. Secondary Auxiliary System	6
	2. Pump System	7
	EXTERNAL DEVICES	8
	Fuel Pumps and Pressure	8
	Air Cleaners	9
SECTION 2:	TUNING PROCEDURE	9
	REVISING THE CALIBRATION	9
	Parts and Equipment	10
	Changing Components	11
	IDLE MIXTURE	11
	Winter Fuel Idle Sets	11
	Long Duration Camshaft.....	12
	CALIBRATING THE	
	WIDE-OPEN THROTTLE (WOT).....	12
	CALIBRATING THE PART THROTTLE	13
	Cruise Mode.....	13
	Power Mode	14
	CALIBRATING THE POWER MODE STAGING	14
	CALIBRATING THE PUMP	14
	FLOAT ADJUSTMENT	14
	CHOKE ADJUSTMENT.....	15
	SPECIAL CALIBRATIONS	16
	CARBURETOR SPECIFICATIONS	16, 17
	CALIBRATION REFERENCE CHARTS	18-31
	APPENDIX	32-38
	Exploded View	32, 33
	Troubleshooting Information.....	34-36
	WARRANTY	37
	EDELBROCK CARBURETOR DATA LOG	38

SECTION 1: THEORY OF OPERATION

BASIC ENGINE REQUIREMENTS

The spark-ignition 4-cycle engine burns a mixture of AIR and FUEL. The air is controlled by the driver's operation of the throttle. The fuel is mixed with the incoming air by the carburetor. The Ratio of AIR to FUEL is the AIR/FUEL Ratio (A/F). This is a ratio by WEIGHT; if 12 pounds of Air are combined with 1 pound of Fuel the A/F is 12:1, or more commonly, $A/F = 12$.

Despite the enormous variety in engine designs, virtually all (spark-ignition 4-Cycle) engines have very similar A/F Ratio requirements. For fully warmed-up engines, the range of A/F is:

<u>A/F RATIO</u>	<u>CHARACTERISTICS</u>
5	RICH BURN LIMIT: Combustion is weak/erratic.
6-9	EXTREMELY RICH: Black smoke and low power.
10-11	VERY RICH: Some supercharged engines run in this range at full power as a means of controlling detonation.
12-13	RICH: Best power A/F: Un-supercharged WOT.
14-15	CHEMICALLY IDEAL: At 14.6 the A/F is at the theoretical ideal ratio with no excess fuel or oxygen after combustion. Good A/F for part throttle cruise and light to moderate acceleration.
16-17	LEAN: Best economy A/F ratio. Borderline for part throttle drivability (worse than borderline if EGR is used).
18-19	VERY LEAN: Usual lean limit (Driveability).
20-25	LEAN BURN LIMIT: Varies with engine and system.

Even though engines will run anywhere between 5 and 25 A/F, the usual target values for an un-supercharged engine are a fairly narrow range (Figure 1). A/F is about 12.5 for the WOT and 14.0-15.5 at part-throttle cruise. An intermediate value of about 13.5-14.0 is usually used for mid-range power (non-WOT acceleration).

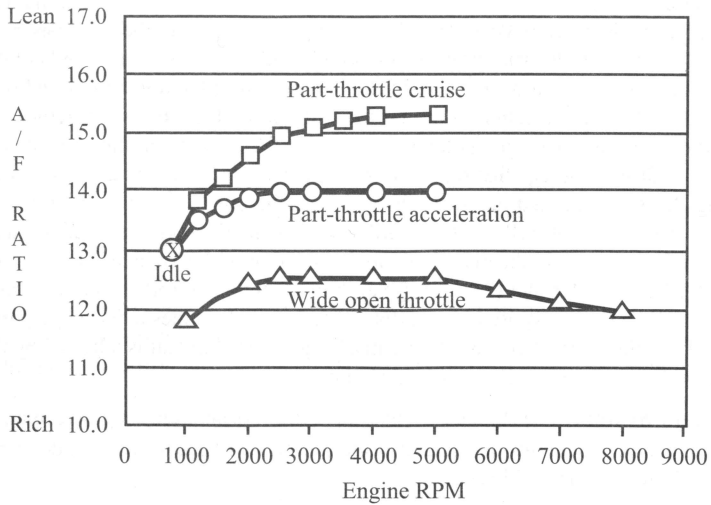

Typical Engine A/F Ratios
Figure 1

METERING SYSTEMS

The Edelbrock carburetor has three (3) basic systems that meter fuel to the engine: The Idle System, Primary Main System, and Secondary Main System. By understanding the operation of each you will be better prepared to calibrate your carburetor.

Idle System: The Idle System delivers 100% of the idle fuel. It also meters fuel at off-idle throttle positions; a large percentage at just off of idle decreasing to a minor influence as the throttle is opened wider. The idle setting is critical both to a smooth idle at proper rpm and to a smooth transition to part-throttle operation.

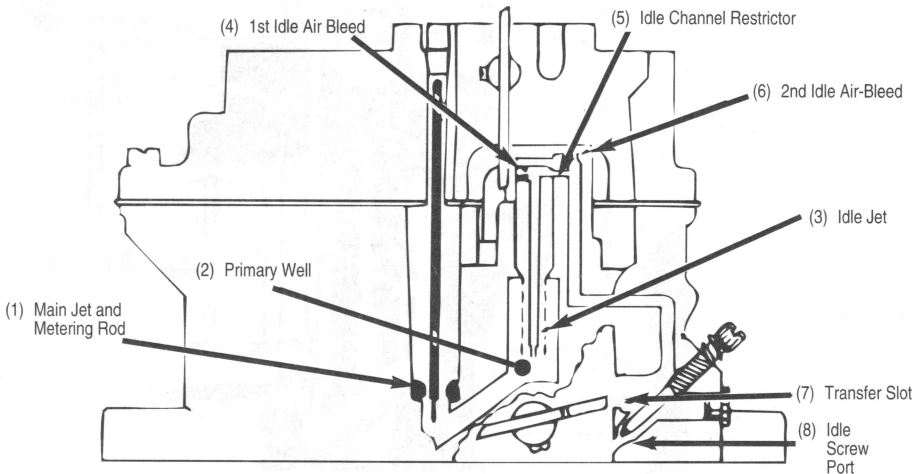

Idle System
Figure 2

Fuel is drawn through the Idle System (Figure 2) by the intake manifold vacuum that is communicated at the Idle Screw Port (8) and Transfer Slot (7). Fuel in the bowl passes through the Primary Main Jet and Metering Rod Restriction (1) and into the Primary Well (2). The fuel for the Idle System is drawn through the restriction at the end of the Idle Jet (3) - a brass tube - and flows up the tube to the location of the 1st Idle Air Bleed (4) - a brass restrictor - where air is mixed with the liquid fuel. The emulsified air and fuel is then drawn through the Idle Channel Restrictor (5) - a drilled passage that serves to increase the velocity of the air and fuel to promote better mixing. As the emulsified fuel is discharged from the Idle Channel Restrictor, additional air is added at the 2nd Idle Air Bleed (6) - a drilled hole - and the highly aerated mixture then moves through the passages in the main-body to the location of the Transfer Slot (7) and Idle Screw Port (8). The Transfer Slot (7) is a large air bleed when the throttle is closed, but as the throttle is opened the slot is exposed to manifold vacuum and becomes a discharge port for Idle System fuel. The Idle Screw Port is a variable discharge restriction that is adjusted by the engine tuner to achieve the desired A/F Ratio at engine idle.

Primary Main System: The Primary Main system delivers an increasing percentage of the fuel as throttle position increases (phasing over the Idle System) and varies fuel delivery in response to air flow and manifold vacuum.

Fuel is drawn through the Main System (Figure 3) by the pressure-drop that occurs when the incoming air flow must increase in velocity in order to pass the reduced throat areas at the Main Venturi (1) and the Boost Venturi (2). This pressure-drop (or suction) is communicated to the system by the Nozzle (3)-a brass tube that opens into the inside of the Booster Venturi (2).

The fuel must pass through the restriction at the Main Jet (4) and Metering Rod (5). The Rod extends through the Jet, reducing the amount of area available for fuel flow. If the diameter of the Rod is large, then fuel flow through the Jet is more restricted than if the Rod were small.

After the Rod and Jet, the fuel enters the Primary Well and is drawn up the inside of the Primary Well Tube (6). Sometimes this tube is called an Emulsion Tube. Here, the fuel is mixed with air that enters the inside of the Tube through a series of small holes. The air is supplied by the Main Well Bleed (7) at the top of the Main Well. The air/fuel mixture exits from the top of the Main Well into a passage that leads it to discharge into the Booster Venturi (2) at the Nozzle (3).

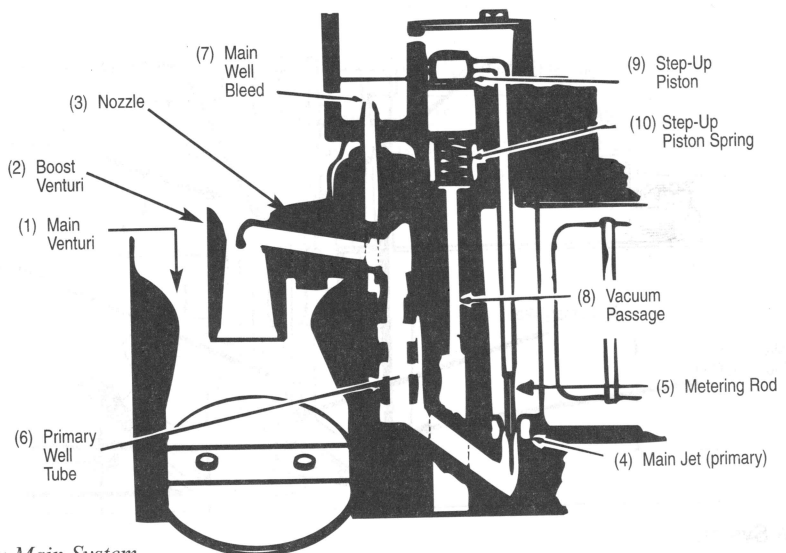

Primary Main System
Figure 3

The fuel flow rate in the Main System is proportional to the air flow rate; as air flow increases - from either an increase in throttle opening or an increase in engine speed at the same throttle opening - the fuel flow also increases by nearly the same degree.

At higher engine loads, such as in a heavy part-throttle acceleration, there is a need for a richer mixture. This enrichment is provided by the Metering Rod and Step-Up Function (Figure 4). A vacuum passage (8) communicates the manifold vacuum to the underside of the Step-Up Piston (9). This vacuum tries to hold the Piston in the bottom of its bore by working against the force of the Step-Up Spring (10).

When the manifold vacuum is high, indicating a low load such as idle, cruise, or light acceleration, it is able to overcome the force of the Step-Up Spring and hold the Step-Up Piston at the bottom of its bore, which also positions the Metering Rod at the bottom of its travel. At this point, the Rod has a large diameter that creates a high restriction through the Jet and the fairly lean A/F Ratio that is desirable for low load/low power operation. This portion of the Metering Rod is referred to as the "Lean Step" of the Rod.

When the manifold vacuum is low, indicating a high load such as a heavy part-throttle (or WOT) acceleration, the Step-Up Spring is able to force the Piston to the top of its bore and position the Metering Rod at the top of its travel. This action is called "Power Mode Staging". The portion of the rod now located in the jet has a smaller diameter, thus the restriction through the Jet is reduced and a rich A/F Ratio is provided for high load/high power operating conditions. This is the "Rich Step" of the Rod.

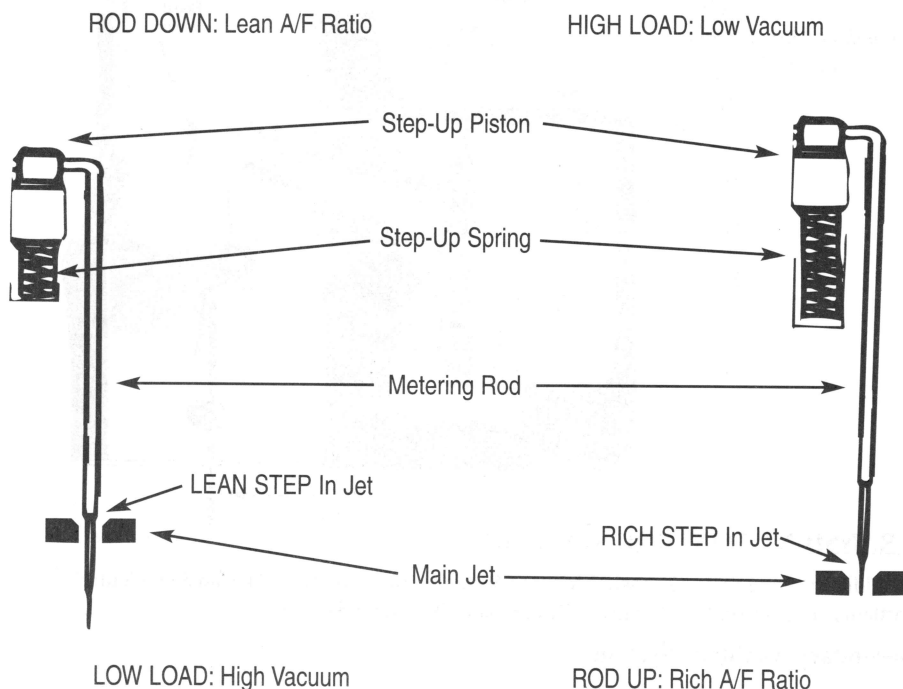

Metering Rod and Step-Up Function

Figure 4

Secondary Main System: The Secondary Main System (Figure 5) delivers fuel only when the secondary throttle blades and air valve are open. It ensures that fuel delivery varies with air flow.

The Secondary Throttles (1) begin to open when the Primaries are about 65% open. The Primary and Secondary Throttles arrive at the WOT stop at the same time.

Air flow through the Secondary side is controlled by Air Valves (2). These valves are located in the secondary bores above the throttle blades. They are balanced against a counter weight and open to admit additional air flow only if there is enough air velocity to allow the proper operation of the Secondary Metering Systems.

The principles of operation for the Secondary Main System are the same as those that govern the operation of the Primary Main System; the pressure drop (suction) arises from the increase in the air velocity as it passes through the Venturi sections. The pressure drop (suction) at the Secondary Booster Venturi (3) is communicated into the system by the Secondary Nozzle (4).

Fuel flows through the Secondary Main Jet (5) to the Secondary Well where it is drawn through the Secondary Well Tube (6). The fuel is mixed with air that enters the tube through a series of small holes. The source of the air is one of the Secondary Well Bleeds (7). There are two air-bleeds; one admits air to the outside of the Well Tube and the other allows air to flow into the passage behind the Nozzle. The fuel, now well mixed with air, flows through the slightly up-hill passage and exits into the Secondary Boost Venturi (3) through the Secondary Nozzle (4).

Secondary Main Systems
Figure 5

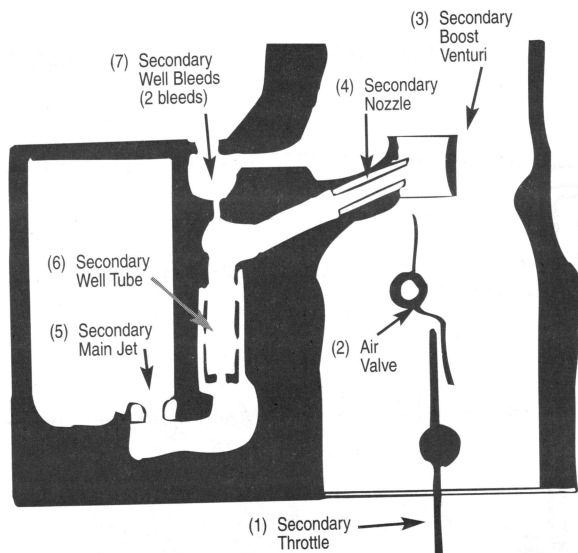

TRANSIENT CONTROL SYSTEMS

In addition to the three (3) basic Metering Systems, there are two (2) Transient Control Systems; The Secondary Auxiliary System and The Pump System.

Secondary Auxiliary System

During the initial stages of Secondary Operation, the air flow rate through the secondaries is very low. Accordingly, there is not enough pressure drop (suction) at the Secondary Nozzle to induce fuel flow. In order to prevent a lean A/F condition that would be experienced by the driver as a

“bog” or “flat spot” on secondary opening, it is necessary to add fuel by an auxiliary means during the time the secondary is in the transient phase.

This is accomplished by placing a small Discharge Nozzle (2) at a point just under the Air Valve (1). The air flow past the edge of the Air Valve creates sufficient pressure drop to pull fuel out of the Auxiliary System. The fuel must first pass through the Secondary Main Jet (3) to the Secondary Well; it is then drawn through the Auxiliary Fuel Tube (4) and exits at the Discharge Nozzle (2). There is always an air-bleed, either in the Auxiliary Fuel Tube (near the top), or as a separate brass restriction bushing (shown).

The flow of fuel in the Auxiliary System is enough to prevent a lean transient on Secondary opening. As the Air Valve is opened further by increasing air flow, the fuel flow through this system decreases. Correspondingly, the fuel flow in the Secondary Main System increases, providing a near constant A/F Ratio.

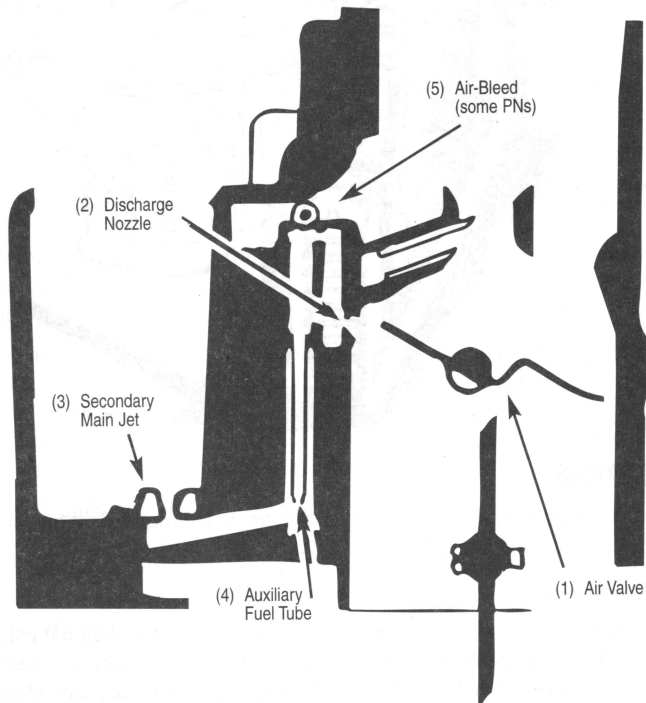

Secondary Auxiliary System
Figure 6

Pump System

When the throttle is opened rapidly, the air flow through the engine will increase immediately. The fuel, since it is much heavier than the air, will “lag” behind. This contributes to a temporary lean A/F condition. Regardless of cause, a solution is to temporarily enrich the A/F Ratio by mechanically pumping a small quantity of fuel into the throat of the carburetor (Figure 7). The Edelbrock carburetor has a piston that draws fuel into the pump cavity past the plunger lip-seal when the throttle is closing (1). Upon opening, the lip-seal seats, allowing the plunger to force the fuel through another one-way valve, the Pump Discharge Ball and Weight (2), and the Pump Jets (3) into the primary throats.

The pump plunger is not driven directly by the throttle, but through an intermediate Pump Drive Spring (4) that extends the duration of the "pump shot" past the time the throttle stops moving. The Edelbrock Performer Series carburetor has an external pump lever with three hole locations for link attachment providing three distinct pump delivery curves. This is further explained in "Calibrating The Pump".

Pump System
Figure 7

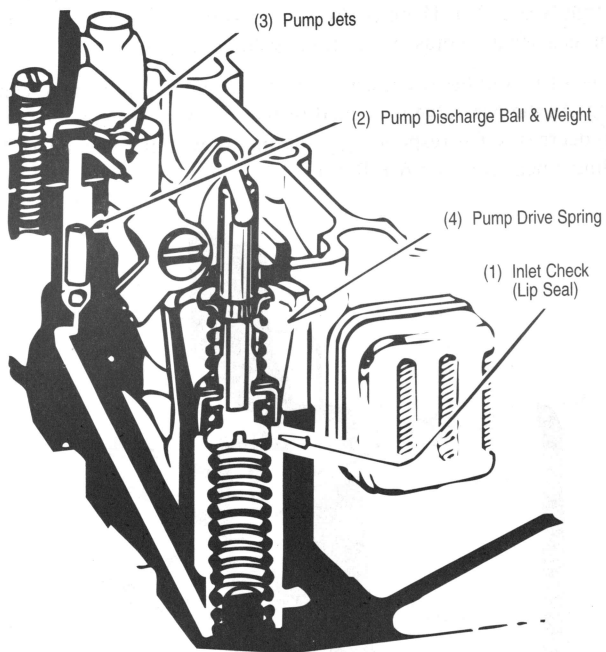

EXTERNAL DEVICES

The function of your Edelbrock Performer Series carburetor is also dependent on several external devices; the fuel pump and air cleaner.

Fuel Pumps and Pressure

Avoid extremes in fuel pressure. At IDLE, there should not be any more than 6.0 psi; if the vehicle has an adjustable fuel-pressure regulator, set it to 5.5 psi. With most fuel pumps the minimum fuel pressure is encountered at high rpm and WOT. Fuel pressure should not drop below 2.0 psi. If it does, a fuel pump with more capacity may be required. Note that some later model vehicles (the 5.0L Ford is one example) have mechanical pumps that will give more than 6.0 psi at idle. The vehicle will perform well, but may be prone to stalls on quick turns and stops with the clutch disengaged. If this problem occurs, check the fuel pressure. If it is more than 6.0 psi at IDLE, it should be reduced through the use of a regulator, such as Edelbrock #8190, or by creating a restricted by-pass bleed to the fuel return line. Edelbrock Street Fuel Pumps are highly recommended for all Edelbrock Performer Series carburetor installations.

Always use a filter, such as Edelbrock #8873 between the pump and carburetor. Note that a good filter is large in area, so it may be able to transmit a significant amount of heat to the fuel. It is a good practice to keep the filter away from heat and not allow it to come in contact with any part of the engine.

Air Cleaners

Your Edelbrock carburetor was originally calibrated with a low restriction open element air cleaner configuration; a 14"x3" Edelbrock Signature Series unit. It was also evaluated for proper metering and vehicle performance using a variety of other air cleaner designs and will perform as intended with nearly any reasonable air cleaner design. While the Edelbrock Performer Series carburetor does not exhibit excessive sensitivity to the air cleaner, there are several guidelines you should follow when selecting an air cleaner:

- Running without an air cleaner is strongly discouraged for a street-driven vehicle. Dirt and varnish will accumulate in critical bleeds and upset the fuel metering. Dirt and debris may easily get into the fuel bowl through the bowl vents or larger bleeds and cause a multitude of problems.
- Any calibration testing should be performed with the air cleaner in place. Depending upon the air cleaner used, the metering typically will be leaner with the air cleaner in place.
- A large 14"x3" open element air cleaner, such as Edelbrock Elite Series, Signature Series and Pro-Flo air cleaners, offers almost no resistance to air flow. Flow bench results show virtually no reduction in air flow. Also, this design should cause no change to the fuel metering.
- A 10"x2" open element design will result in some definite air flow restriction but little change to the fuel metering.
- Elements smaller than 10"x2" are more restrictive and have the most effect upon metering. The fuel metering at WOT will be shifted LEANER, especially at higher rpm ranges.
- If you have a dual-purpose vehicle that is sometimes used in competition without an air cleaner, it may be necessary to have two separate calibrations. If you are running a smaller air cleaner and have optimized the WOT with it in place, do not be surprised to find that the metering shifts RICHER when the air cleaner is removed. This may require you to calibrate the WOT with leaner Jets and Rods at the drag strip.
- DO NOT allow the vehicle air-stream to blow across the top of the carburetor(s) such as on an open-bodied car or full-bodied vehicle with a tunnel-ram manifold. The flow of air across the carburetor will result in an upset to the fuel metering that cannot be accommodated by recalibration since the change to the A/F Ratio will be different for every vehicle speed.

SECTION 2 : TUNING PROCEDURE

Before proceeding please ensure you have installed your Edelbrock Performer Series Carburetor according to the *Carburetor Installation Instructions* included with the carburetor

REVISING THE CALIBRATION

The Edelbrock Performer Series Carburetor is designed to allow quick and easy changes to the metering. Virtually any change imaginable can be performed without removing the carburetor from the manifold, and the most common changes may be performed in less than five minutes without removal of the airhorn (bowl cover).

To help you calibrate your carburetor, a CALIBRATION REFERENCE CHART has been designed for each model of the Edelbrock Performer Series carburetor. These charts (pages 18—31) each consist of two sections: A Calibration Table and a Rod/Jet Reference Chart.

After reading the Calibration procedures, the next step in calibrating your carburetor is to look at the Calibration Table for your model carburetor. Determine if you would like to go richer or leaner in the Cruise Mode and do the same for the Power Mode. Select the number that is closest to intersection of your Cruise and Power Mode selections. This is your calibration reference number. Now refer to the Rod/Jet Reference Chart that appears on the opposing page. Locate your calibration reference number to determine the rod/jet combination for your application.

For example, you have a 1405 Edelbrock Performer Series carburetor. You have determined (by reading the rest of the manual) you would like to go 1 stage lean in the Cruise Mode and 2 stages lean in the Power Mode. The intersection of these two lines lies on the number 21. This is your calibration reference number. Now look below the Calibration Table to the Rod/Jet Reference Chart. Find the number 21 under the REF# column. The jets you should use are .098 and the rods are .070 x .052.

Located at the very bottom of each Calibration Reference Chart is a guide for changing your Secondary Metering. This will be useful when calibrating the wide-open-throttle (WOT).

Before you attempt to establish a new calibration, be sure that the engine is in a sound state of tune. All ignition items must be in proper working order, including reasonably fresh plugs of the correct heat range. Timing should be properly set and the air filter element and fuel filter should be clean.

Proper fuel pressure should be verified and cracked or brittle vacuum lines should be eliminated. Many so-called "carburetor calibration" problems have been traced to another part of the engine system that was not functioning properly.

CAUTION: *Be alert to carburetor flooding when fuel is first applied. Flooding can be caused by dirt, small particles of hose cuttings, floats and inlet needles which have settled during shipping, or by other conditions as discussed below. Each Edelbrock Performer Series carburetor is flow tested in the factory for both air and liquid flow so flooding is rare. However, for safety sake please observe this caution. When the fuel pump is turned on or when the engine is first started, watch closely for signs of flooding. If flooding is apparent, tap the body of the carburetor lightly with a rawhide mallet or the wooden handle of a small hammer. If flooding continues, pinch the fuel line hose to shut off flow, run the engine to clear the carburetor, and let the fuel line flow again. If flooding continues, pinch the fuel line hose to shut off flow, run the engine to clear the carburetor, and let the fuel line flow again. If flooding still continues, stop the engine. Clean up any raw gasoline and refer to the "Trouble Shooting" section of the Owner's Manual.*

Parts and Equipment —

Aside from ordinary hand tools, the following items are recommended.

- Edelbrock Performer Series Carburetor Jet Set - Contains selections of Main Jets, Metering Rods, and Springs.
- Tachometer - If the vehicle is not equipped with a tach, the dwell meter style tach will be adequate. If neither is available, you will be able to use the speedometer in place of the tach for some of the procedures, but it will not be as convenient.
- Vacuum Gauge - Should be hooked up to read engine's intake manifold vacuum. Without a vacuum gauge, some of the calibration procedures will be more difficult.

Changing Components

Metering Rod and Step-Up Spring changes can typically be made in less than five minutes and without removing the carburetor. First, loosen the Step-Up Piston Cover Screws (See pg. 32) and twist the Step-Up Piston Cover Plates to the side. The Metering Rods and Step-Up Springs can now be removed and replaced if necessary. Be sure to replace the Step-Up Piston Cover Plate and tighten the Step-Up Piston Cover Screw when finished.

CAUTION: Do not overtighten the Step-Up Piston Cover Screws! They should only be tightened to **12 to 17 inch/pounds**. Excessive torque will weaken or snap off the screw heads. If this happens, they may fall into the carb causing serious engine damage. If an inch/pound torque wrench is not available, snug the screw until it just touches the plate, then tighten 1/16th turn more.

To replace the Primary or Secondary Metering Jets, first, remove the Metering Rods and Step-Up Springs as outlined in the preceding paragraph. Next, disconnect the Choke Cam Connector Rod, Pump Connector Rod, and Choke Connector Rod (when applicable). Finally, remove the 8 Airhorn Attaching Screws and remove the Airhorn from the carburetor body. A standard screwdriver can now be used to remove the appropriate Metering Jets. Once desired Metering Jets have been installed the carb may be reassembled by reversing this procedure.

IDLE MIXTURE

The Edelbrock Performer Series carburetor has conventional Idle Mixture Screws (IMS) that provide a leaner A/F when turned clockwise and richer A/F when turned counter clockwise. The idle air flow is controlled by a conventional screw that opens the Primary Throttles. The following procedure should be used to set the idle mixture and speeds.

1. Fully warm engine and ensure choke is fully open.
2. Air cleaner in place.
3. Set desired speed with the air screw.
4. Adjust the IMS on ONE side to get the maximum possible RPM. Do not go rich beyond the maximum speed point.
5. If the above changed the idle speed more than 40 RPM, then readjust the speed.
6. Adjust the side OPPOSITE of that in Step 4 to get maximum RPM.
7. Reset the speed.
8. Carefully trim each IMS to again get the maximum idle RPM.
9. Go leaner just enough to get a 20 RPM drop in speed.
10. Reset the speed to the desired RPM.
11. This is a Lean-Best Idle Set. Setting richer than this will not improve idle quality or performance, but could tend to foul plugs.

Winter Fuel Idle Sets

During the winter months (in most parts of the country) the local fuel will be a "winter" blend that is very volatile, as an assist to cold-engine starting and driveability during warm-up. However, the high volatility has the disadvantage of allowing excessive vaporization of the fuel if the vehicle is operated in a heated area such as a garage. This can result in problems in the idle-set procedures since the carburetor's internal vents will allow this excess vapor to be drawn into the throats and enrichen the mixture. The idle will be erratic and not seem to be able to hold a set. To resolve this type of problem, it is advisable to perform the final settings outdoors after the vehicle has been stabilized with a drive of several miles.

Long Duration Camshaft

If the engine has a fairly radical camshaft it may require an excessive amount of throttle opening for idle and/or have low idle vacuum levels. Either condition can lead to poor levels of adjustability and erratic idles.

- Another fix for the above condition is to run as much spark advance as possible at idle. If the distributor is fitted with a vacuum advance unit, connect it directly to manifold vacuum. If you are not able to employ vacuum advance for some reason, then the mechanical curve should have a low limit, which will allow you to use plenty of initial spark advance.
- Measure the manifold vacuum at idle. If it is below 7" Hg, there is a good chance that the Metering Rods are in the up (rich) position. When combined with a high idle air rate this can cause the Nozzles to discharge fuel at idle. Use a weaker Step-Up Spring (see section on Step-Up calibration) to keep the Rods down at idle. With some cams, a stiffer spring (pink or silver) is necessary. Experimentation is the best way to determine which is best for your application.

CALIBRATING THE WIDE-OPEN-THROTTLE (WOT)

The best place to perform your WOT calibration is on a chassis dyno. If one is not available then consider a safe, legal driving space, such as a drag strip where you are given E.T. and MPH data.

1. Select an RPM Range to use in evaluating the WOT power. As a rule, use the highest 50 percent of the real power band. If your engine makes good power up to 5000 RPM, then 2500-5000 is a good range. If peak power is at 6500, then 3500-6500 would be a good pick. Be sure not to select RPMs that are higher than the engine's useful power band.
2. Accelerate at WOT from 1000 RPM below the range you have elected to a few hundred over the range. Time the acceleration with a stop-watch. Be sure to time only the interval while the engine is sweeping through the selected range. Make enough timed accelerations to get a good average that is not affected by wind or grade.
3. Refer to the Calibration Reference Chart for your model. Find the richest Power Mode (Primary Metering) change you can make without changing a Jet — a Rod change only. This will probably be 2 stages (8%) rich.
4. Change to the indicated Rods. Perform timed acceleration #2. Compare the times. Do not be surprised if there is no difference.
5. Compare the results of timed acceleration #2 to the base calibration and refer to the following section that best describes your situation:

Case 1: Faster than base calibration

Change Secondaries 2 stages richer and perform acceleration test #3.

- If test #3 is the same as #2, you're done.
- If test #3 is slower than #2, change to 1 stage rich for the Primary and Secondary and you're done.
- If test #3 is still faster than #2, go to 3 stages rich Primary and Secondary and keep going richer until there is no change (or slower) in the times. Stay at the first "no change" level,

so that you stay with the richer of any two levels of calibration that have the same power.

Case 2: Slower than base calibration

Go to 1 stage lean Primaries and 1 lean Secondaries and perform acceleration test #3.

- If test #3 is the same as base calibration, go back to the base calibration.
- If test #3 is faster than base calibration, go to 2 stages lean on both the Primaries and the Secondaries. Keep going in the lean direction until there is no change or slower then back up 1 stage richer, so that you stay with the richer of any two levels of calibration that have the same power.

Case 3: Same as base calibration

Do not be surprised. Change back to base calibration.

CALIBRATING THE PART-THROTTLE

The Metering Rod feature used in the Edelbrock Performer allows easy calibration of the part-throttle without change to the WOT metering.

- Cruise Mode: The power output is low, as in a steady cruise light acceleration. Manifold Vacuum is high and the Metering Rods are down in the lean position.
- Power Mode: The power output is high, as in a heavy but not wide-open acceleration. Manifold Vacuum is low and the Rods are up in the rich position.

As explained in the “Theory of Operation,” the Step-Up function modulates the Rods between the Cruise and Power positions.

The part-throttle calibration is more “individualized” than is the Wide-Open-Throttle (WOT). It is not measured by absolute numbers, but reflects the driver’s feel for a particular combination.

Carefully evaluate the driveability with the carburetor at the calibration level determined from the WOT exercise. Drive at a variety of engine speeds and throttle openings looking for any flat spots or lean/surge conditions.

Cruise Mode

If there are any surge or flat spot conditions in the steady speed cruises or light accelerations, a lean condition probably exists. Consult the Calibration Reference Chart and change to 1 stage rich in the Cruise Mode. If it gets better, but not completely fixed, keep going in the rich direction. The Calibration Reference Chart will give you Rod and Jet combinations that are directionally correct or you may choose your own.

If the light throttle is satisfactory, trying going 1 stage lean in the Cruise Mode. If there are still no problems with surge or other indications of lean metering, do not hesitate to go to 2 stages lean in the Cruise Mode. A lean Cruise Mode has advantages in fuel economy and keeping the plugs clean. Keep going until you begin to notice driveability problems and then back up 1 stage.

Power Mode

Accelerations at part-throttle with low manifold vacuum (less than about 5” Hg on a vacuum gauge) are metered by the Power Mode. Avoid calibrating this portion of the engine’s operating range too lean as spark knock (detonation) and piston/valve burning can occur. If this mode has any lean driveability symptoms (surge or flat spots), it is too lean and should be recalibrated at least 1 stage richer.

CALIBRATING THE POWER MODE STAGING

The Step-Up function, which moves the Metering Rod to the Power Mode, is controlled by the Step-Up Spring. The base calibration has a spring which "stages" rich at 5" Hg.

If your vehicle has a mid-throttle driveability problem that is encountered as the throttle is gradually opened, but then goes away upon further opening, it may be possible to eliminate the lean spot by using a stronger Step-Up Spring. The available Step-Up Springs are listed in the following chart along with their respective "staging" point. It is best to select a new spring on the basis of vacuum readings, but in the absence of a gauge, try the strongest spring (highest vacuum rating) to see if the problem goes away. If the drive problem is cured by the strong spring, try the next weakest spring as well. If the strong one does not help, then the calibration problem is related to the A/F metering stage of either the Cruise or Power Modes. Use the Calibration Reference Chart to help select another combination.

Spring Color	Blue	Yellow	Orange	Pink	Plain
Staging Vacuum ("Hg)	3"	4"	5"	7"	8"

A complete set of these springs is available separately as Edelbrock part #1464.

CALIBRATING THE PUMP

If you encounter any hesitations or stumbles that do not seem to be related to the basic metering or have not responded to changes in the basic metering, move the pump drive link to one of the holes closer to the carburetor body. This will increase the stroke length of the plunger and result in more pump delivery.

FLOAT ADJUSTMENT

To properly adjust the floats in the EPS carburetor, two procedures must be followed. First, invert the airhorn cover (Figure 8) holding the airhorn gasket in place. There should be 7/16" between the airhorn gasket and the top of the outer end of the float. To adjust the float level, bend the float lever until the recommended level is attained. DO NOT press the needle into the seat when adjusting the float lever. Next, you should check the float drop (Figure 9). Hold the airhorn upright and let the floats hang down. There should be 15/16" to 1" between the airhorn gasket and the top of the outer end of the float. To adjust the float drop, bend the tab on the back until the recommended float drop is attained. For the off-road float adjustment, see page 16.

CHOKE ADJUSTMENT

To adjust the choke piston linkage (Figure 10) open the choke valve and insert a .026" wire, with a 90 degree bend 1/8" from the end, between the top of the slot in the choke piston cylinder and the bottom of the slot in the piston. Hold the wire in position and close the choke valve by pressing on piston lever A until resistance is felt. The dimension C should be .100" between the top edge of the choke valve and the air horn. To adjust, bend rod B.

To adjust the fast idle linkage (Figure 11) place the fast idle screw A between the two notches on the cam. Close the choke valve as far as possible without forcing it. The dimension C should be 3/64" between the choke valve and the air horn. To adjust bend rod D.

Fast idle may be adjusted to manufacturers specifications (usually 1500 rpm) during normal choke cold operation. The fast idle screw A can be adjusted with engine off and throttle held open to allow screw head access. Recheck fast idle speed after each adjustment.

BEND HERE

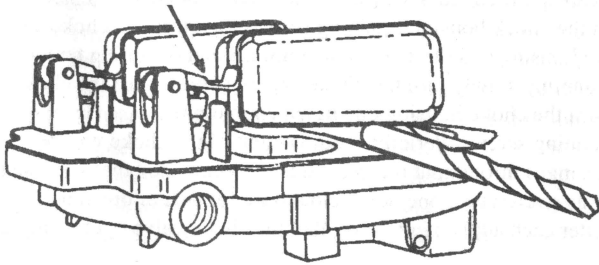

Float Level (7/16")
Figure 8

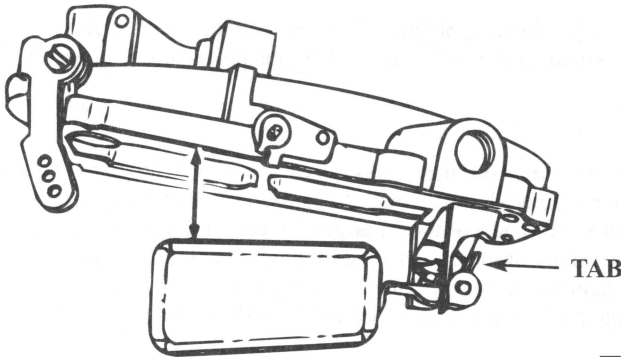

Float Drop (15/16" to 1")
Figure 9

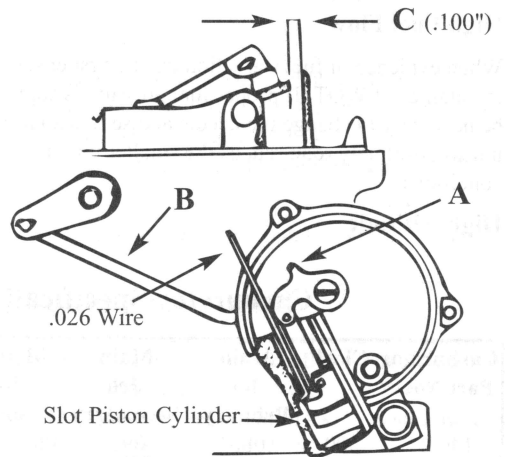

Choke piston linkage
Figure 10

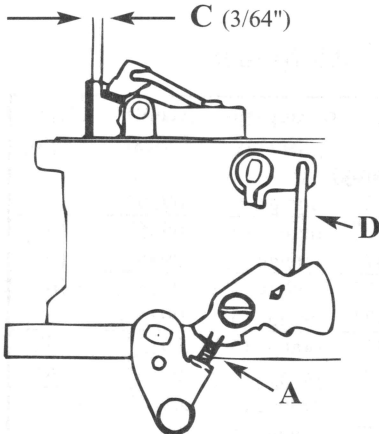

Fast idle linkage
Figure 11

The length of time during which the choke will stay closed is determined by the position of the choke cap. As the choke cap is turned clockwise the choke will stay closed longer. To properly set the choke loosen the choke housing retaining screws then turn the choke cap to the leanest notch on the choke housing and run the engine until normal operating temperature is reached. With the engine running, slowly turn the choke cap clockwise until the choke valve begins to close. Now turn the choke housing one notch counterclockwise (lean) and tighten the choke housing retaining screws. Periodic readjustment of the choke will be required as the temperature changes throughout the year. It is recommended that you use the notches in the choke housing as a reference, one notch clockwise for rich or one notch counterclockwise for lean. After each adjustment verify that the choke valve opens fully after the engine is warm.

SPECIAL CALIBRATIONS

The preceding calibrations and adjustments apply to carburetors used in general street applications. In the following extreme instances, special calibration procedures may need to be followed.

Off-Road

Although the Edelbrock Performer Series carburetor was not calibrated with hill climbing and other extreme off-road operation in mind, it can be made to perform superbly by substituting Edelbrock #1465 spring loaded needle and seat for the original needle and seat. The spring loaded needle and seat act like a shock absorber, reducing the possibility of flooding during off-road operation. After installation of the new needle and seat you must reset the float level to 7/16" and drop the float drop to 15/16 to 1" as outlined in "FLOAT ADJUSTMENT".

High Fuel Flow

When evidence of fuel starvation exists, first ensure that proper pressure (4-5 psi minimum) is maintained at WOT. If proper fuel pressure is supplied and fuel starvation still exists, it may be necessary to change the needle and seat to a larger size (#1466). Do not make this change unless absolutely required, as the smaller inlet is preferred for proper fuel control under most conditions.

High Altitude

Carburetor Specifications - All Models

Carburetor Part No.	CFM	Main Jet Primary	Main Jet Secondary	Metering Rod (Primary only)	Step-Up Spring	Needle & Seat	Float Height
1403	500	.086"	.095"	.065" x .052"	orange (5")	.0935"	7/16"
1404	500	.086"	.095"	.065" x .052"	orange (5")	.0935"	7/16"
1405	600	.100"	.095"	.070" x .047"	orange (5")	.0935"	7/16"
1406	600	.098"	.095"	.075" x .047"	yellow (4")	.0935"	7/16"
1407	750	.113"	.107"	.071" x .047"	orange (5")	.0935"	7/16"
1409*	600	.098"	.101"	.068" x .047"	orange (5")	.0935"	7/16"
1410*	750	.113"	.107"	.071" x .047"	orange (5")	.0935"	7/16"
1411	750	.110"	.107"	.075" x .047"	orange (5")	.0935"	7/16"
1412	800	.113"	.101"	.071" x .047"	orange (5")	.0935"	7/16"
1413	800	.113"	.101"	.071" x .047"	orange (5")	.0935"	7/16"

* = Carburetor is certified to meet U.S. Coast Guard Requirements

Altitude has a direct effect on the operation of most carburetors. As the altitude increases, the air becomes less dense so a carburetor, originally calibrated at low altitude, delivers too much fuel and the engine runs richer. If the preceding tuning procedure is performed on an Edelbrock Performer Series carburetor, a proper high altitude calibration will result. If the vehicle was calibrated at lower altitude, however, and is to be driven at high altitude temporarily, it is not necessary to repeat the complete calibration procedure. Instead, use the rule of: "2% leaner per 1500 feet" and the Calibration Reference Chart for your model carburetor. For example, with a #1405 at baseline calibration (location #1 on the chart) and intended operation at 6000 ft. altitude, you would want 6000 divided by 1500 x 2% = 8% leaner calibration. That would be location #24 on the chart which would require only a rod and jet change.

Blended Fuels

Typically, two types of blended fuels are available: Gasohol and gasahol. Gasohol is a blend of not more than 10% ethanol and gasoline. As long as there is no more than 10% ethanol mixed with the gasoline you carburetor will function properly. As the percentage of ethanol climbs above 10%, a richer A/F ratio will be required. Also, because gasohol is more volatile than gasoline, hard hot starting and poor hot weather driveability may result.

Gasahol can be a blend of either ethanol, methanol or other alcohol with gasoline. Methanol blended fuel should not be used in your Edelbrock Performer Series carburetor as it will cause corrosion of the fuel system components. It can also cause rapid failure of seals, gaskets, diaphragms and pump plungers.

Always check to see if you are using a blended fuel. Although the pump may not indicate the fuel is blended, it is always advisable to verify the type of fuel the station carries.

Blown Engines

Two model #1405 carburetors should be used on engines with positive displacement superchargers, such as GMC 6-71 blowers or equivalent. The following calibration changes make an excellent starting point: Primary Jets - .101" (#1429); Secondary Jets - .101" (#1429); Metering Rods - .070" x .042" (#1450); Step-up Piston Springs - 5" (orange, stock); Needle & Seat assemblies - .110" (#1466).

This calibration has been tested on engines ranging in size from 350 c.i.d. Chevys to 440 c.i.d. Chryslers with good results.

Carburetor Specifications (continued)

Float Drop (±1/4")	Pump Link Location	Drive Pump Nozzle Diameter	Accelerator Pump Diameter	Venturi Diameter Primaries	Venturi Diameter Secondaries	Throttle Bore Diameter Primaries	Throttle Bore Diameter Secondary
1-1/4"	middle hole	.028"	.028"	1-3/16"	1-9/16"	1-7/16"	1-11/16"
1-1/4"	middle hole	.028"	.028"	1-3/16"	1-9/16"	1-7/16"	1-11/16"
1-1/4"	middle hole	.028"	.028"	1-3/16"	1-9/16"	1-7/16"	1-11/16"
1-1/4"	middle hole	.031"	.031"	1-3/16"	1-9/16"	1-7/16"	1-11/16"
1-1/4"	top hole	.035"	.035"	1-7/16"	1-9/16"	1-11/16"	1-11/16"
1-1/4"	middle hole	.028"	.028"	1-3/16"	1-9/16"	1-7/16"	1-11/16"
1-1/4"	top hole	.035"	.035"	1-7/16"	1-9/16"	1-11/16"	1-11/16"
1-1/4"	top hole	.035"	.035"	1-7/16"	1-9/16"	1-11/16"	1-11/16"
1-1/4"	top hole	.035"	.035"	1-17/32"	1-5/8"	1-3/4"	1-3/4"
1-1/4"	top hole	.035"	.035"	1-17/32"	1-5/8"	1-3/4"	1-3/4"

#1403 / 1404 Calibration Reference Chart / Primary Metering

Power Mode: Low Vacuum/High Power-Rod Up

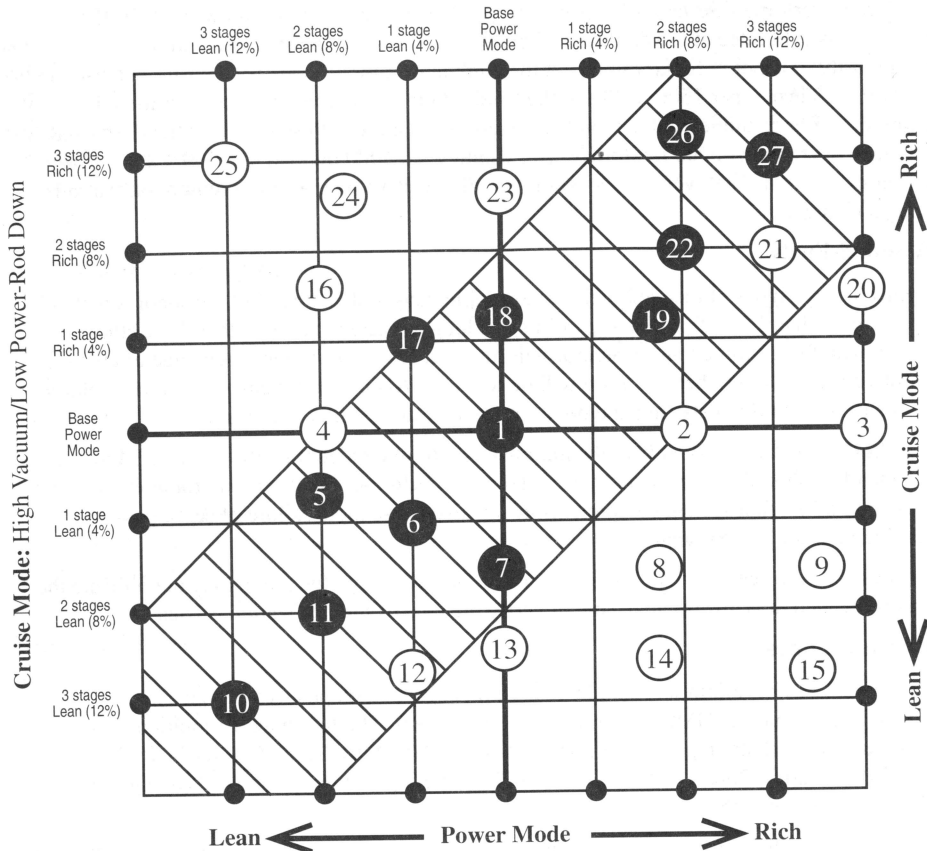

- 1 Stock Calibration
- # Numbers in black are the steps obtainable using Calibration Kit #1486 plus the stock jets and metering rods.
- # Numbers in white are the steps obtainable using jet and rod combinations shown on the following page.

- Step 1 Select the combination of Cruise Mode and Power Mode fuel-metering stages desired for your calibration. Normal calibration changes will be within the gridded diagonal area. That is, Cruise and Power mode changes should be in the same direction (either richer or leaner) and usually by the same amount.
- Step 2 Find the number that is nearest your desired combination. This is your Calibration Reference Number.
- Step 3 Go to the next page. Find the Calibration Reference Number you have just selected in Step 2. Listed will be the Main Jet and Metering Rod required to achieve the desired fuel metering for the Primaries.

Model #1403 & #1404 Rod/Jet Reference Chart

REF #	MAIN JET	METERING ROD	CHANGE FROM BASE
1	1423 (.086)	1460 (065 x 052)	none - stock calibration
2	1423 (.086)	1445 (065 x 047)	Rod
3	1423 (.086)	1444 (065 x 037)	Rod
4	1423 (.086)	1461 (065 x 057)	Rod
5	1422 (.083)	1441 (062 x 052)	Rod & Jet
6	1423 (.086)	1463 (067 x 055)	Rod
7	1423 (.086)	1448 (068 x 052)	Rod
8	1423 (.086)	1447 (068 x 047)	Rod
9	1423 (.086)	1446 (068 x 042)	Rod
10	1422 (.083)	1463 (067 x 055)	Rod & Jet
11	1422 (.083)	1460 (065 x 052)	Jet
12	1422 (.083)	1462 (067 x 049)	Rod & Jet
13	1423 (.086)	1452 (070 x 052)	Rod
14	1423 (.086)	1451 (070 x 047)	Rod
15	1423 (.086)	1450 (070 x 042)	Rod
16	1422 (.083)	1438 (058 x 052)	Rod & Jet
17	1422 (.083)	1437 (057 x 049)	Rod & Jet
18	1423 (.086)	1441 (062 x 052)	Rod
19	1423 (.086)	1443 (063 x 047)	Rod
20	1423 (.086)	1442 (063 x 037)	Rod
21	1424 (.089)	1445 (065 x 047)	Rod & Jet
22	1424 (.089)	1460 (065 x 052)	Jet
23	1423 (.086)	1439 (060 x 052)	Rod
24	1423 (.086)	1440 (060 x 057)	Rod
25	1422 (.083)	1436 (055 x 055)	Rod & Jet
26	1424 (.089)	1441 (062 x 052)	Rod & Jet
27	1424 (.089)	1443 (063 x 047)	Rod & Jet

Secondary Metering

The factory calibration jet is shown in the center column. For leaner or richer calibration use the jet # indicated in the appropriate column.

3 Stages Lean (12%)	2 Stages Lean (8%)	1 Stage Lean (4%)	SECONDARY Stock Calibration	1 Stage Rich (4%)	2 Stages Rich (8%)	3 Stages Rich (12%)
JET #1423 (.086)	JET #1424 (.089)	JET #1425 (.092)	JET #1426 (.095)	JET #1427 (.098)	JET #1429 (.101)	JET #1430 (.104)

Main Jet I.D.—All Edelbrock jets have "120-" prefix. The last three digits minus 300 = actual jet size.

Examples: 120-386 = .086" jet (Edelbrock p/n 1423).
120-401 = .101" jet (Edelbrock p/n 1429).

#1405 Calibration Reference Chart / Primary Metering

Power Mode: Low Vacuum/High Power-Rod Up

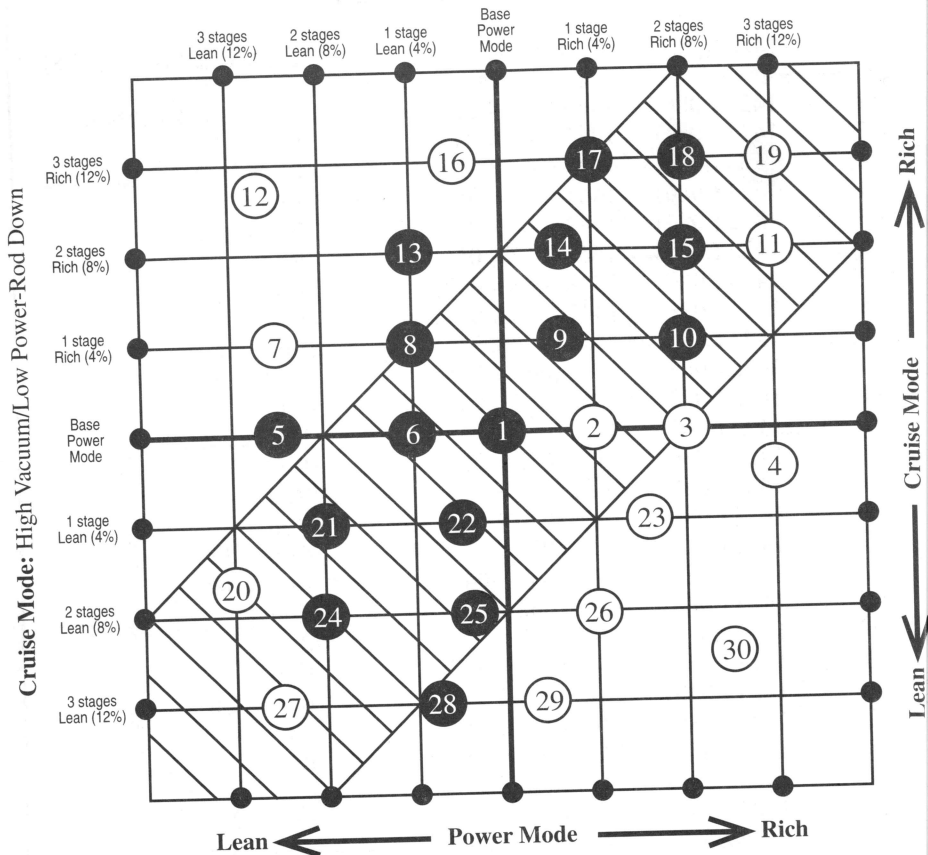

- 1 Stock Calibration
- # Numbers in black are the steps obtainable using **Calibration Kit #1479** plus the stock jets and metering rods.
- # Numbers in white are the steps obtainable using jet and rod combinations shown on the following page.

- Step 1 Select the combination of Cruise Mode and Power Mode fuel-metering stages desired for your calibration. Normal calibration changes will be within the gridded diagonal area. That is, Cruise and Power mode changes should be in the same direction (either richer or leaner) and usually by the same amount.
- Step 2 Find the number that is nearest your desired combination. This is your Calibration Reference Number.
- Step 3 Go to the next page. Find the Calibration Reference Number you have just selected in Step 2. Listed will be the Main Jet and Metering Rod required achieve the desired fuel metering for the Primaries.

Model #1405

Rod/Jet Reference Chart

<u>REF #</u>	<u>MAIN JET</u>	<u>METERING ROD</u>	<u>CHANGE FROM BASE</u>
1	1428 (.100)	1451 (070 x 047)*	none - stock calibration
		*Some Have ID #695	
2	1428 (.100)	1450 (070 x 042)	Rod
3	1428 (.100)	1449 (070 x 037)	Rod
4	1430 (.104)	1458 (075 x 037)	Rod & Jet
5	1427 (.098)	1448 (068 x 052)	Rod & Jet
6	1428 (.100)	1452 (070 x 052)	Rod
7	1427 (.098)	1445 (065 x 047)	Rod & Jet
8	1428 (.100)	1448 (068 x 052)	Rod
9	1428 (.100)	1446 (068 x 042)	Rod
10	1430 (.104)	1459 (075 x 047)	Rod & Jet
11	1430 (.104)	1455 (073 x 042)	Rod & Jet
12	1427 (.098)	1441 (062 x 052)	Rod & Jet
13	1429 (.101)	1448 (068 x 052)	Rod & Jet
14	1430 (.104)	1457 (073 x 052)	Rod & Jet
15	1430 (.104)	1456 (073 x 047)	Rod & Jet
16	1428 (.100)	1445 (065 x 047)	Rod
17	1430 (.104)	1452 (070 x 052)	Rod & Jet
18	1430 (.104)	1451 (070 x 047)*	Jet
		*Some Have ID #695	
19	1430 (.104)	1450 (070 x 042)	Rod & Jet
20	1426 (.095)	1445 (065 x 047)	Rod & Jet
21	1427 (.098)	1452 (070 x 052)	Rod & Jet
22	1428 (.100)	1457 (073 x 052)	Rod
23	1428 (.100)	1455 (073 x 042)	Rod
24	1427 (.098)	1457 (073 x 052)	Rod & Jet
25	1428 (.100)	1459 (075 x 047)	Rod
26	1427 (.098)	1449 (070 x 037)	Rod & Jet
27	1426 (.095)	1446 (068 x 042)	Rod & Jet
28	1427 (.098)	1456 (073 x 047)	Rod & Jet
29	1427 (.098)	1455 (073 x 042)	Rod & Jet
30	1429 (.101)	1458 (075 x 037)	Rod & Jet

Secondary Metering

The factory calibration jet is shown in the center column. For leaner or richer calibration use the jet # indicated in the appropriate column.

3 Stages Lean (12%)	2 Stages Lean (8%)	1 Stage Lean (4%)	SECONDARY Stock Calibration	1 Stage Rich (4%)	2 Stages Rich (8%)	3 Stages Rich (12%)
JET #1423 (.086)	JET #1424 (.089)	JET #1425 (.092)	JET #1426 (.095)	JET #1427 (.098)	JET #1429 (.101)	JET #1430 (.104)

Main Jet I.D.—All Edelbrock jets have "120-" prefix. The last three digits minus 300 = actual jet size.

Examples:

120-398 = .098" jet (Edelbrock p/n 1427).

120-400 = .100" jet (Edelbrock p/n 1428).

#1406 Calibration Reference Chart / Primary Metering

Power Mode: Low Vacuum/High Power-Rod Up

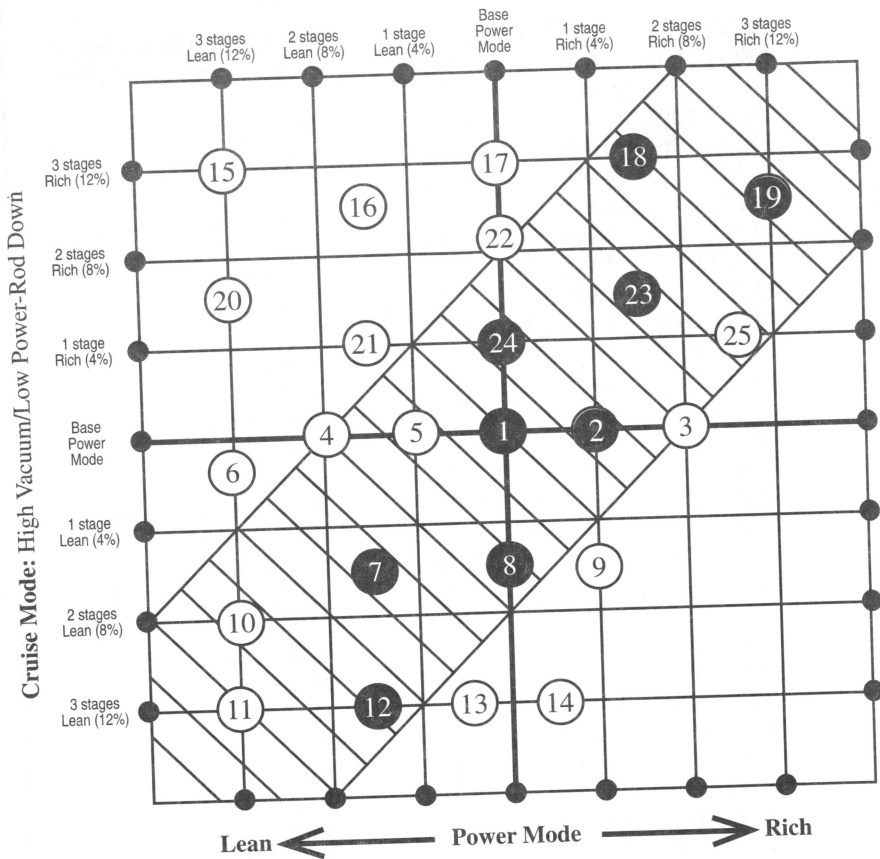

1 Stock Calibration

Numbers in black are the steps obtainable using Calibration Kit #14 plus the stock jets and metering rods.

Numbers in white are the steps obtainable using jet and rod combinations shown on the following page.

- Step 1 Select the combination of Cruise Mode and Power Mode fuel-metering stages desired for your calibration. Normal calibration changes will be within the gridded diagonal area. That is, Cruise and Power mode changes should be in the same direction (either richer or leaner) and usually by the same amount.
- Step 2 Find the number that is nearest your desired combination. This is your Calibration Reference Number.
- Step 3 Go to the next page. Find the Calibration Reference Number you have selected in Step 2. Listed will be the Main Jet and Metering Rod required to achieve the desired fuel metering for the Primaries.

Model #1406 Rod/Jet Reference Chart

REF #	MAIN JET	METERING ROD	CHANGE FROM BASE
1	1427 (.098)	1459 (075 x 047)	none - stock calibration
2	1426 (.095)	1449 (070 x 037)	Rod & Jet
3	1427 (.098)	1458 (075 x 037)	Rod
4	1425 (.092)	1446 (068 x 042)	Rod & Jet
5	1426 (.095)	1453 (071 x 047)	Rod & Jet
6	1425 (.092)	1447 (068 x 047)	Rod & Jet
7	1426 (.095)	1456 (073 x 047)	Rod & Jet
8	1426 (.095)	1455 (073 x 042)	Rod & Jet
9	1426 (.095)	1454 (073 x 037)	Rod & Jet
10	1425 (.092)	1451 (070 x 047)	Rod & Jet
11	1425 (.092)	1453 (071 x 047)	Rod & Jet
12	1426 (.095)	1459 (075 x 047)	Jet
13	1425 (.092)	1449 (070 x 037)	Rod & Jet
14	1426 (.095)	1458 (075 x 037)	Rod & Jet
15	1426 (.095)	1448 (068 x 052)	Rod & Jet
16	1426 (.095)	1447 (068 x 047)	Rod & Jet
17	1427 (.098)	1453 (071 x 047)	Rod
18	1429 (.101)	1459 (075 x 047)	Jet
19	1427 (.098)	1449 (070 x 037)	Rod
20	1425 (.092)	1445 (065 x 047)	Rod & Jet
21	1426 (.095)	1451 (070 x 047)	Rod & Jet
22	1426 (.095)	1446 (068 x 042)	Rod & Jet
23	1427 (.098)	1455 (073 x 042)	Rod
24	1427 (.098)	1456 (073 x 047)	Rod
25	1427 (.098)	1454 (073 x 037)	Rod

Secondary Metering

The factory calibration jet is shown in the center column. For leaner or richer calibration use the jet # indicated in the appropriate column.

3 Stages Lean (12%)	2 Stages Lean (8%)	1 Stage Lean (4%)	SECONDARY Stock Calibration	1 Stage Rich (4%)	2 Stages Rich (8%)	3 Stages Rich (12%)
JET #1423 (.086)	JET #1424 (.089)	JET #1425 (.092)	JET #1426 (.095)	JET #1427 (.098)	JET #1429 (.101)	JET #1430 (.104)

Main Jet I.D.—All Edelbrock jets have "120-" prefix. The last three digits minus 300 = actual jet size.

Examples: 120-398 = .098" jet (Edelbrock p/n 1427).
120-401 = .101" jet (Edelbrock p/n 1429).

#1407 / #1410 Calibration Reference Chart / Primary Metering

Power Mode: Low Vacuum/High Power-Rod Up

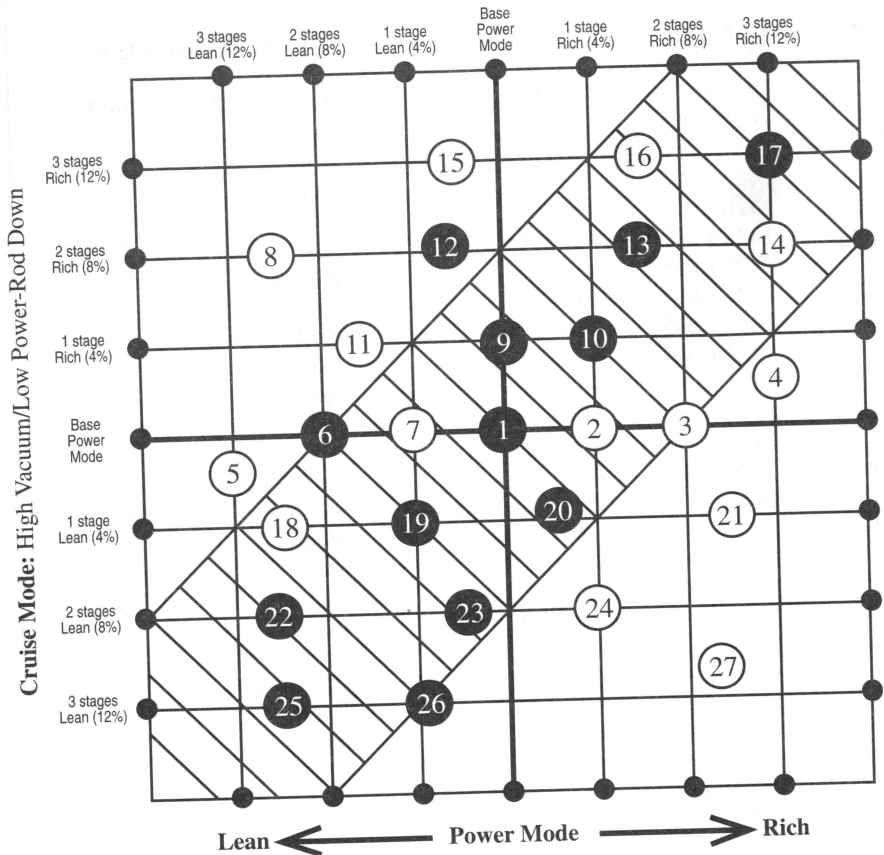

- ① Stock Calibration
- # Numbers in black are the steps obtainable using **Calibration Kit #148** plus the stock jets and metering rods.
- # Numbers in white are the steps obtainable using jet and rod combination shown on the following page.

- Step 1 Select the combination of Cruise Mode and Power Mode fuel-metering stages desired for your calibration. Normal calibration changes will be within the gridded diagonal area. That is, Cruise and Power mode changes should be in the same direction (either richer or leaner) and usually by the same amount.
- Step 2 Find the number that is nearest your desired combination. This is your Calibration Reference Number.
- Step 3 Go to the next page. Find the Calibration Reference Number you have just selected in Step 2. Listed will be the Main Jet and Metering Rod required to achieve the desired fuel metering for the Primaries.

Model #1407 & #1410

Rod/Jet Reference Chart

<u>REF #</u>	<u>MAIN JET</u>	<u>METERING ROD</u>	<u>CHANGE FROM BASE</u>
1	1433 (.113)	1453 (071 x 047)	none - stock calibration
2	1433 (.113)	1450 (070 x 042)	Rod
3	1433 (.113)	1449 (070 x 037)	Rod
4	1434 (.116)	1454 (073 x 037)	Rod & Jet
5	1431 (.107)	1443 (063 x 047)	Rod & Jet
6	1432 (.110)	1445 (065 x 047)	Rod & Jet
7	1433 (.113)	1452 (070 x 052)	Rod
8	1432 (.110)	1441 (062 x 052)	Rod & Jet
9	1433 (.113)	1447 (068 x 047)	Rod
10	1434 (.116)	1456 (073 x 047)	Rod & Jet
11	1432 (.110)	1443 (063 x 047)	Rod & Jet
12	1433 (.113)	1445 (065 x 047)	Rod
13	1434 (.116)	1453 (071 x 047)	Jet
14	1434 (.116)	1449 (070 x 037)	Rod & Jet
15	1433 (.113)	1443 (063 x 047)	Rod
16	1433 (.113)	1442 (063 x 037)	Rod
17	1434 (.116)	1444 (065 x 037)	Rod & Jet
18	1432 (.110)	1452 (070 x 052)	Rod & Jet
19	1433 (.113)	1457 (073 x 052)	Rod
20	1433 (.113)	1456 (073 x 047)	Rod
21	1433 (.113)	1454 (073 x 037)	Rod
22	1431 (.107)	1445 (065 x 047)	Rod & Jet
23	1431 (.107)	1444 (065 x 037)	Rod & Jet
24	1432 (.110)	1449 (070 x 037)	Rod & Jet
25	1431 (.107)	1447 (068 x 047)	Rod & Jet
26	1432 (.110)	1456 (073 x 047)	Rod & Jet
27	1432 (.110)	1454 (073 x 037)	Rod & Jet

Secondary Metering

The factory calibration jet is shown in the center column. For leaner or richer calibration use the jet # indicated in the appropriate column.

3 Stages Lean (12%)	2 Stages Lean (8%)	1 Stage Lean (4%)	SECONDARY Stock Calibration	1 Stage Rich (4%)	2 Stages Rich (8%)	3 Stages Rich (12%)
JET #1427 (.098)	JET #1429 (.101)	JET #1430 (.104)	JET #1431 (.107)	JET #1432 (.110)	JET #1433 (.113)	JET #1434 (.116)

Main Jet I.D.—All Edelbrock jets have "120-" prefix. The last three digits minus 300 = actual jet size.

Examples:

120-398 = .098" jet (Edelbrock p/n 1427).

120-413 = .113" jet (Edelbrock p/n 1433).

#1409 Calibration Reference Chart / Primary Metering

Power Mode: Low Vacuum/High Power-Rod Up

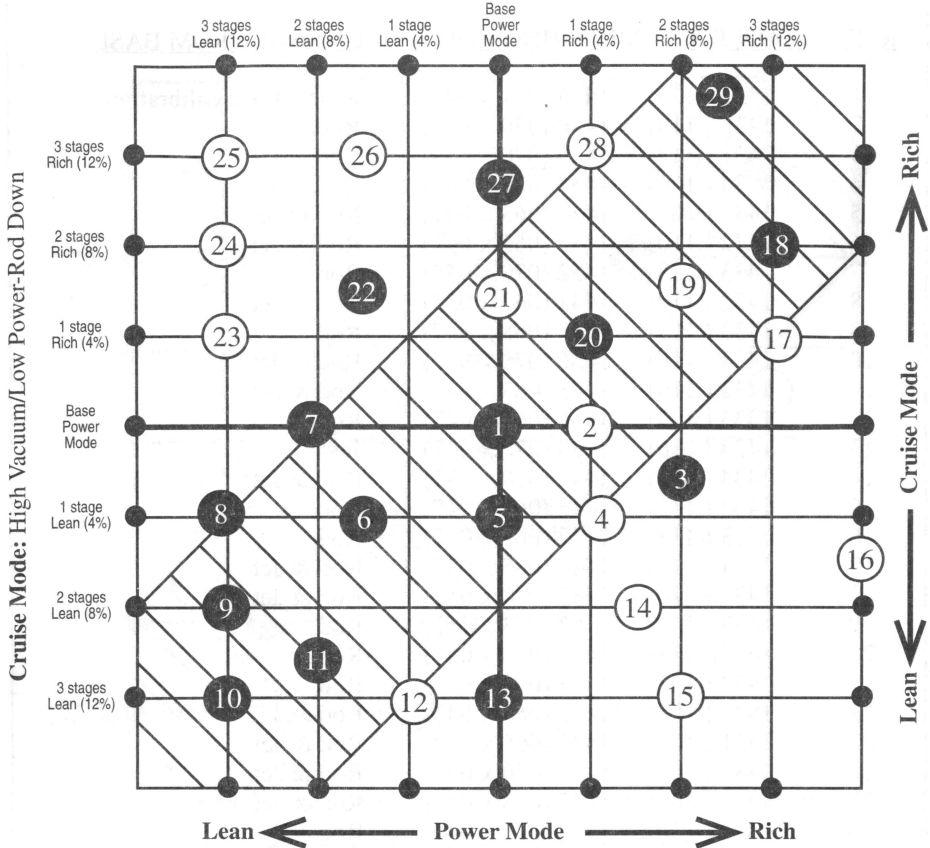

- ① Stock Calibration
- # Numbers in black are the steps obtainable using **Calibration Kit #1488** plus the stock jets and metering rods.
- # Numbers in white are the steps obtainable using jet and rod combinations shown on the following page.

- Step 1 Select the combination of Cruise Mode and Power Mode fuel-metering stages desired for your calibration. Normal calibration changes will be within the gridded diagonal area. That is, Cruise and Power mode changes should be in the same direction (either richer or leaner) and usually by the same amount.
- Step 2 Find the number that is nearest your desired combination. This is your Calibration Reference Number.
- Step 3 Go to the next page. Find the Calibration Reference Number you have just selected in Step 2. Listed will be the Main Jet and Metering Rod required to achieve the desired fuel metering for the Primaries.

Model #1409
Rod/Jet Reference Chart

<u>REF #</u>	<u>MAIN JET</u>	<u>METERING ROD</u>	<u>CHANGE FROM BASE</u>
1	1427 (.098)	1447 (068 x 047)	none - stock calibration
2	1427 (.098)	1446 (068 x 042)	Rod
3	1429 (.101)	1456 (073 x 047)	Rod & Jet
4	1427 (.098)	1450 (070 x 042)	Rod
5	1427 (.098)	1451 (070 x 047)	Rod
6	1427 (.098)	1452 (070 x 052)	Rod
7	1426 (.095)	1443 (063 x 047)	Rod & Jet
8	1426 (.095)	1460 (065 x 052)	Rod & Jet
9	1425 (.092)	1443 (063 x 047)	Rod & Jet
10	1426 (.095)	1452 (070 x 052)	Rod & Jet
11	1426 (.095)	1447 (068 x 047)	Jet
12	1425 (.092)	1444 (065 x 037)	Rod & Jet
13	1427 (.098)	1456 (073 x 047)	Rod
14	1429 (.101)	1459 (075 x 047)	Rod & Jet
15	1427 (.098)	1454 (073 x 037)	Rod
16	1429 (.101)	1458 (075 x 037)	Rod & Jet
17	1430 (.104)	1459 (075 x 047)	Rod & Jet
18	1430 (.104)	1456 (073 x 047)	Rod & Jet
19	1427 (.098)	1444 (065 x 037)	Rod
20	1429 (.101)	1451 (070 x 047)	Rod & Jet
21	1427 (.098)	1445 (065 x 047)	Rod
22	1427 (.098)	1460 (065 x 052)	Rod
23	1426 (.095)	1441 (062 x 052)	Rod & Jet
24	1426 (.095)	1439 (060 x 052)	Rod & Jet
25	1426 (.095)	1438 (058 x 052)	Rod & Jet
26	1427 (.098)	1441 (062 x 052)	Rod
27	1427 (.098)	1443 (063 x 047)	Rod
28	1429 (.101)	1462 (067 x 049)	Rod & Jet
29	1430 (.104)	1452 (070 x 052)	Rod & Jet

Secondary Metering

The factory calibration jet is shown in the center column. For leaner or richer calibration use the jet # indicated in the appropriate column.

3 Stages Lean (12%)	2 Stages Lean (8%)	1 Stage Lean (4%)	SECONDARY Stock Calibration	1 Stage Rich (4%)	2 Stages Rich (8%)	3 Stages Rich (12%)
JET #1425 (.092)	JET #1426 (.095)	JET #1427 (.098)	JET #1429 (.101)	JET #1430 (.104)	JET #1431 (.107)	JET #1432 (.110)

Main Jet I.D.—All Edelbrock jets have "120-" prefix. The last three digits minus 300 = actual jet size.

Examples:

120-398 = .098" jet (Edelbrock p/n 1427).

120-401 = .101" jet (Edelbrock p/n 1429).

#1411 Calibration Reference Chart / Primary Metering

Power Mode: Low Vacuum/High Power-Rod Up

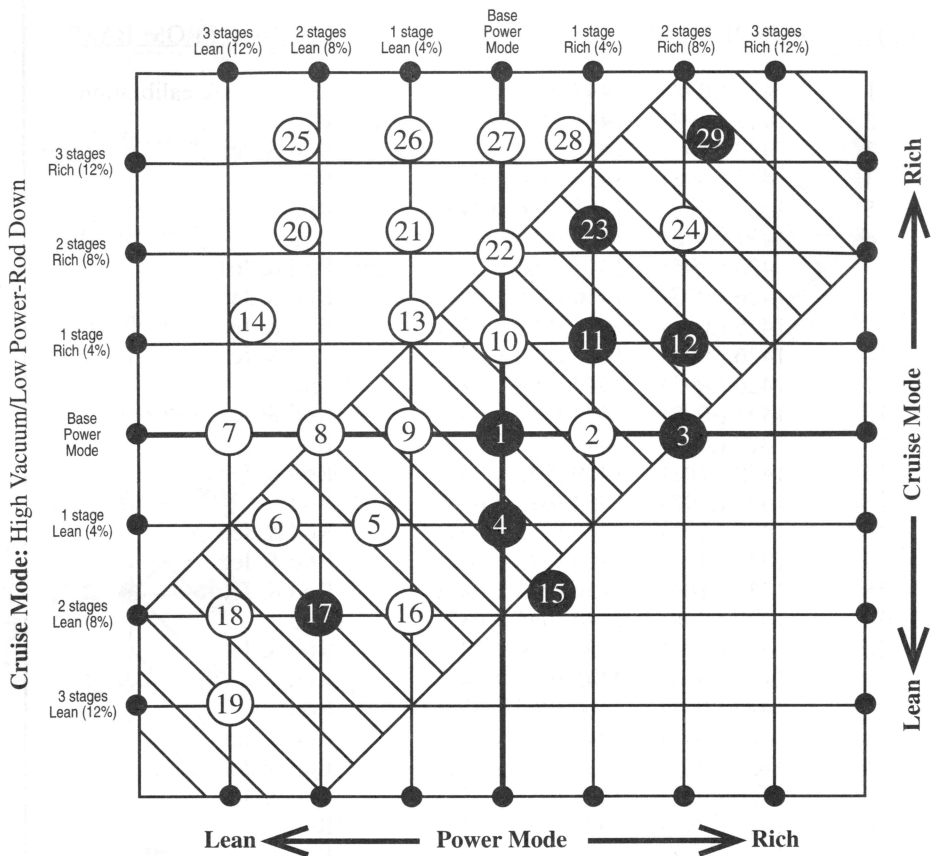

- 1 Stock Calibration
- # Numbers in black are the steps obtainable using **Calibration Kit #1489** plus the stock jets and metering rods.
- # Numbers in white are the steps obtainable using jet and rod combinations shown on the following page.

- Step 1 Select the combination of Cruise Mode and Power Mode fuel-metering stages desired for your calibration. Normal calibration changes will be within the gridded diagonal area. That is, Cruise and Power mode changes should be in the same direction (either richer or leaner) and usually by the same amount.
- Step 2 Find the number that is nearest your desired combination. This is your Calibration Reference Number.
- Step 3 Go to the next page. Find the Calibration Reference Number you have just selected in Step 2. Listed will be the Main Jet and Metering Rod required to achieve the desired fuel metering for the Primaries.

Model #1411

Rod/Jet Reference Chart

<u>REF #</u>	<u>MAIN JET</u>	<u>METERING ROD</u>	<u>CHANGE FROM BASE</u>
1	1432 (.110)	1459 (075 x 047)	none - stock calibration
2	1432 (.110)	1419 (075 x 042)	Rod
3	1432 (.110)	1458 (075 x 037)	Rod
4	1431 (.107)	1454 (073 x 037)	Rod & Jet
5	1431 (.107)	1456 (073 x 047)	Rod & Jet
6	1431 (.107)	1457 (073 x 052)	Rod & Jet
7	1430 (.104)	1445 (065 x 047)	Rod & Jet
8	1430 (.104)	1416 (065 x 042)	Rod & Jet
9	1430 (.104)	1444 (065 x 037)	Rod & Jet
10	1432 (.110)	1456 (073 x 047)	Rod
11	1432 (.110)	1455 (073 x 042)	Rod
12	1432 (.110)	1454 (073 x 037)	Rod
13	1431 (.107)	1447 (068 x 047)	Rod & Jet
14	1431 (.107)	1448 (068 x 052)	Rod & Jet
15	1431 (.107)	1458 (075 x 037)	Rod & Jet
16	1430 (.104)	1449 (070 x 037)	Rod & Jet
17	1430 (.104)	1450 (070 x 042)	Rod & Jet
18	1430 (.104)	1451 (070 x 047)	Rod & Jet
19	1430 (.104)	1453 (071 x 047)	Rod & Jet
20	1432 (.110)	1418 (070 x 057)	Rod
21	1432 (.110)	1452 (070 x 052)	Rod
22	1432 (.110)	1453 (071 x 047)	Rod
23	1432 (.110)	1450 (070 x 042)	Rod
24	1432 (.110)	1449 (070 x 037)	Rod
25	1432 (.110)	1417 (068 x 057)	Rod
26	1432 (.110)	1448 (068 x 052)	Rod
27	1432 (.110)	1447 (068 x 047)	Rod
28	1432 (.110)	1446 (068 x 042)	Rod
29	1433 (.113)	1455 (073 x 042)	Rod & Jet

Secondary Metering

The factory calibration jet is shown in the center column. For leaner or richer calibration use the jet # indicated in the appropriate column.

3 Stages Lean (12%)	2 Stages Lean (8%)	1 Stage Lean (4%)	SECONDARY Stock Calibration	1 Stage Rich (4%)	2 Stages Rich (8%)	3 Stages Rich (12%)
JET #1427 (.098)	JET #1429 (.101)	JET #1430 (.104)	JET #1431 (.107)	JET #1432 (.110)	JET #1433 (.113)	JET #1434 (.116)

Main Jet I.D.—All Edelbrock jets have "120-" prefix. The last three digits minus 300 = actual jet size.

Examples:

120-398 = .098" jet (Edelbrock p/n 1427).

120-413 = .113" jet (Edelbrock p/n 1433).

#1412 & #1413 Calibration Reference Chart / Primary Metering

Power Mode: Low Vacuum/High Power-Rod Up

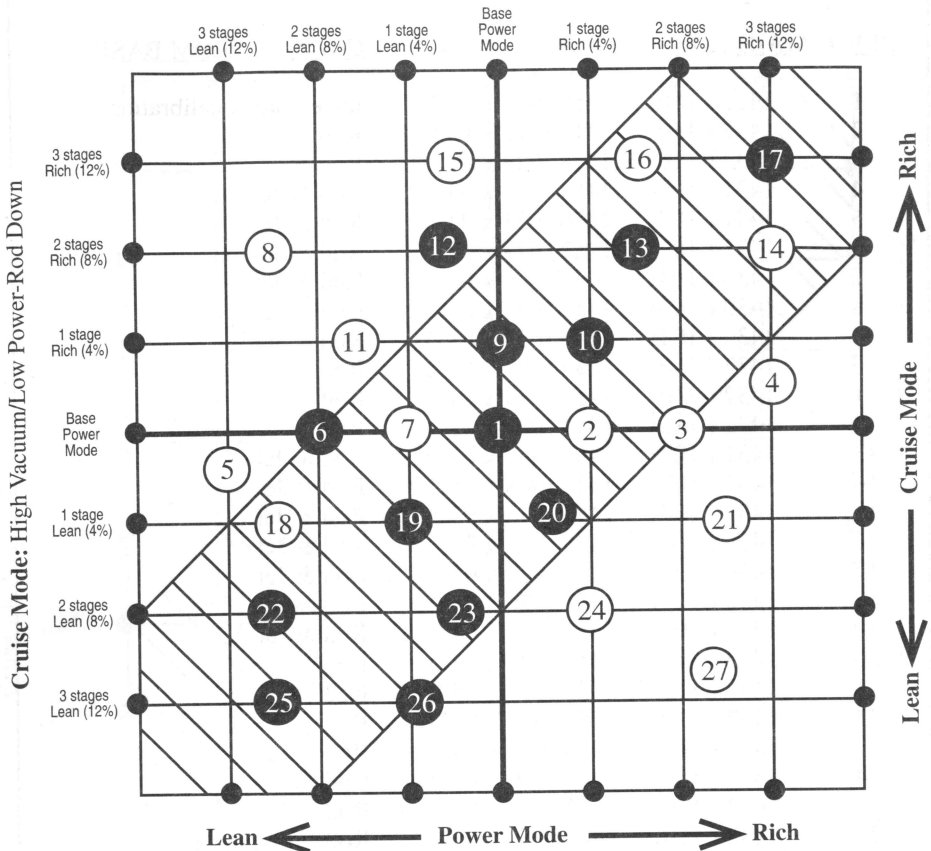

- 1 Stock Calibration
- # Numbers in black are the steps obtainable using **Calibration Kit #1480** plus the stock jets and metering rods.
- # Numbers in white are the steps obtainable using jet and rod combinations shown on the following page.

- Step 1 Select the combination of Cruise Mode and Power Mode fuel-metering stages desired for your calibration. Normal calibration changes will be within the gridded diagonal area. That is, Cruise and Power mode changes should be in the same direction (either richer or leaner) and usually by the same amount.
- Step 2 Find the number that is nearest your desired combination. This is your Calibration Reference Number.
- Step 3 Go to the next page. Find the Calibration Reference Number you have just selected in Step 2. Listed will be the Main Jet and Metering Rod required to achieve the desired fuel metering for the Primaries.

Model #1412 & #1413

Rod/Jet Reference Chart

<u>REF #</u>	<u>MAIN JET</u>	<u>METERING ROD</u>	<u>CHANGE FROM BASE</u>
1	1433 (.113)	1453 (071 x 047)	none - stock calibration
2	1433 (.113)	1450 (070 x 042)	Rod
3	1433 (.113)	1449 (070 x 037)	Rod
4	1434 (.116)	1454 (073 x 037)	Rod & Jet
5	1431 (.107)	1443 (063 x 047)	Rod & Jet
6	1432 (.110)	1445 (065 x 047)	Rod & Jet
7	1433 (.113)	1452 (070 x 052)	Rod
8	1432 (.110)	1441 (062 x 052)	Rod & Jet
9	1433 (.113)	1447 (068 x 047)	Rod
10	1434 (.116)	1456 (073 x 047)	Rod & Jet
11	1432 (.110)	1443 (063 x 047)	Rod & Jet
12	1433 (.113)	1445 (065 x 047)	Rod
13	1434 (.116)	1453 (071 x 047)	Jet
14	1434 (.116)	1449 (070 x 037)	Rod & Jet
15	1433 (.113)	1443 (063 x 047)	Rod
16	1433 (.113)	1442 (063 x 037)	Rod
17	1434 (.116)	1444 (065 x 037)	Rod & Jet
18	1432 (.110)	1452 (070 x 052)	Rod & Jet
19	1433 (.113)	1457 (073 x 052)	Rod
20	1433 (.113)	1456 (073 x 047)	Rod
21	1433 (.113)	1454 (073 x 037)	Rod
22	1431 (.107)	1445 (065 x 047)	Rod & Jet
23	1431 (.107)	1444 (065 x 037)	Rod & Jet
24	1432 (.110)	1449 (070 x 037)	Rod & Jet
25	1431 (.107)	1447 (068 x 047)	Rod & Jet
26	1432 (.110)	1456 (073 x 047)	Rod & Jet
27	1432 (.110)	1454 (073 x 037)	Rod & Jet

Secondary Metering

The factory calibration jet is shown in the center column. For leaner or richer calibration use the jet # indicated in the appropriate column.

3 Stages Lean (12%)	2 Stages Lean (8%)	1 Stage Lean (4%)	SECONDARY Stock Calibration	1 Stage Rich (4%)	2 Stages Rich (8%)	3 Stages Rich (12%)
JET #1425 (.092)	JET #1426 (.095)	JET #1427 (.098)	JET #1429 (.101)	JET #1430 (.104)	JET #1431 (.107)	JET #1432 (.110)

Main Jet I.D.—All Edelbrock jets have "120-" prefix. The last three digits minus 300 = actual jet size.

Examples: 120-398 = .098" jet (Edelbrock p/n 1427).
120-413 = .113" jet (Edelbrock p/n 1433).

Exploded View of Edelbrock Performer Series Carburetor

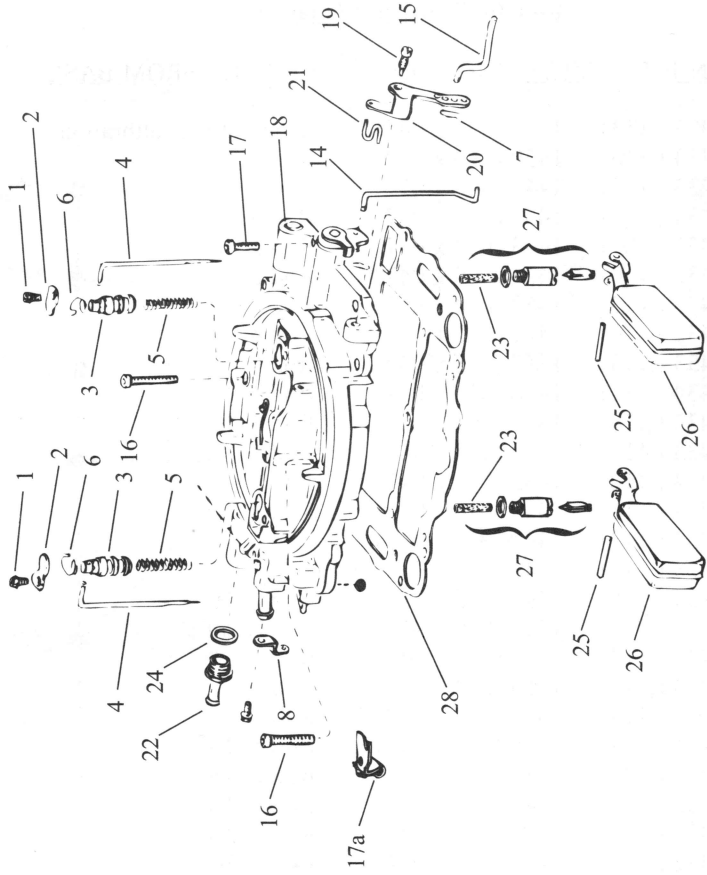

Item Description

1. Step-up piston cover screws (2)
2. Step-up piston cover plates (2)
3. Step-up pistons (2)
4. Step-up (metering) rods (2)
5. Step-up piston springs (2)
6. Step-up rod retainer springs (2)
7. Pin springs (small) (3)
8. Choke connector rod & lever*
9. Choke piston housing*
- 9a. Choke piston housing seal*
- 9b. Choke filter*
10. Mounting screws (3)
- 10a. Choke housing retainers (3)*
11. Thermostatic coil assembly*
12. Baffle plate*
13. Choke housing gasket*
14. Choke/cam connector rod
15. Pump connector rod
16. Airhorn attaching screw (1)
17. Airhorn attaching screws (8)
18. Airhorn assembly
19. Pump arm screw
20. Pump arm
21. Pump connector link
22. Fuel inlet fitting
23. Fuel Strainer Screens (2)
24. Fuel inlet fitting gasket
25. Float lever pins (2)
26. Float & lever assemblies (2)
27. Fuel inlet fitting gasket
28. Choke housing seal

27. Needle & seat assemblies (2)
28. Airhorn gasket
29. Pump plunger assembly
30. Pump plunger spring
31. Primary cluster screws (4)
32. Primary venturi boosters (2)
33. Venturi booster gaskets (2)
34. Pump jet housing screws (2)
35. Pump jet housing
36. Pump jet housing gasket
37. Pump discharge weight
38. Pump discharge ball
39. Secondary booster screws (4)
40. Secondary venturi boosters (2)
41. Venturi booster gaskets (2)
42. Air valve & weights
43. Primary metering jets (2)
44. Secondary metering jets (2)
45. Fuel bowl baffle plates (2)
46. Idle mixture screws & springs (2)
47. Fast idle cam
48. Idle speed screw
49. Body assembly
50. Ported vacuum port
51. Full-time vacuum port
52. PCV valve port

**Electric choke models 1406, 1409, 1410, &1411*

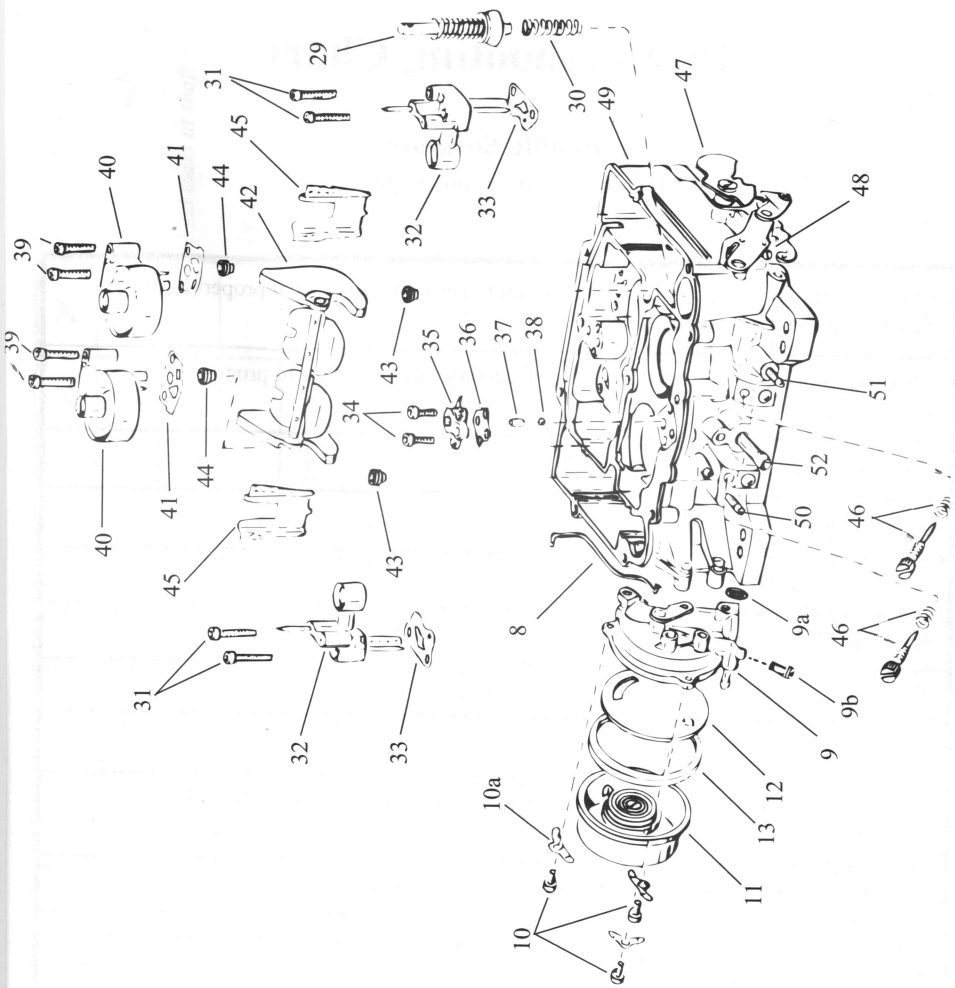

Troubleshooting Chart

Possible Solution

(Symptoms on opposite page)

Check for air leaks. Make sure carburetor and manifold gaskets seal properly. All outlets must be plugged or connected.
Check ignition system. Replace parts as necessary. Adjust timing to proper specifications.
Check choke adjustment. See page 14.
Change carburetor fuel filter and/or in-line fuel filter.
Too lean. See <i>Tuning Procedure</i> .
Check float level and drop. See page 14.
Check idle mixture screw adjustment. See page 11.
Too rich. See <i>Tuning Procedure</i> .
Increase accelerator pump stroke. Pump squirter size change may be needed. See page 14.
Off-road vehicle may need spring-loaded needle and seat kit (pg. 16).
Check for dirt or metal in needles and seats. Needles and seats may need replacement. See page 36.
Check for dirt blocking the low speed circuit. Clean unit and apply air pressure. Install in-line fuel filter #8873.
Check floats for leakage. Replace if necessary.
Check air horn gasket. Replace if deterioration or breakage is present.
Fuel is boiling due to excessive under hood temperature. See page 36.
Fuel pressure too high. Fuel regulator may be needed. See page 8.
Fuel pressure too low. Check fuel system. See page 8.
Check secondary latching device and rod for proper movement.
Lower float level from 11/32" to 7/16". See page 14.

Symptoms

Carburetor doesn't adjust properly
 Carburetor floods
 Fuel leaks at shaft
 Internal fuel leak
 Misses or surges
 Stumbles or loads up
 Engine won't idle
 Rough idle
 Backfires
 Bogs
 Hard starting
 Lack of power
 Pinging at moderate cruise just off idle
 Engine stalls on hard braking
 Low fuel economy

X				X		X	X	X	X		X	X		X
X				X		X	X	X		X		X		X
				X	X	X	X	X			X			X
	X				X					X	X	X		
				X					X		X	X		
	X	X			X								X	X
X						X	X							X
					X				X					X
					X						X			
	X	X												
	X		X											X
X						X						X		X
	X		X										X	X
	X		X										X	X
		X								X				X
	X		X										X	X
				X							X			
										X				
											X			
												X		

Troubleshooting Information

Dirt/metal shavings between the needle and seat or a “sticking float”: To correct either of these problems, lightly tap the carburetor fuel inlet area with the handle of a screwdriver. If flooding continues, pinch the fuel line (if possible). Start the engine and let it run until it stops. Release line and restart engine. If flooding persists examine the needles, seats, float level, and float drop. Adjust or replace parts if necessary.

Excessive under hood temperature: Ensure fuel line is not located too close to heat sources such as the exhaust or block, causing expanding fuel to be forced past the needle and seat. Fuel can also boil inside the carburetor due to missing gaskets, spacers, or heat shields. Also check to see if the exhaust heat riser is stuck, allowing excessive heat under the carburetor. Use Edelbrock Divided Heat Insulator Gasket #9266 for dual-plane manifolds, Square-Bore Heat Insulator Gasket #9265 for single-plane manifolds, and #9267 Heat Insulator Gaskets for dual-quad manifolds.

Excessive fuel pump pressure: See page 8.

**For further information contact the
Edelbrock Technical Department:
Between 7:00 am and 5:00 pm PST,
Monday through Friday
Tech Line: (800) 416-8628 • Offices: (310) 781-2222
FAX (310) 320-1187**



WARRANTY

EDELBROCK warrants its *Performer Series* Carburetors to be free from defects in material or workmanship. This warranty is valid provided that the product is properly installed, subjected to normal use and service and is not modified or changed in any way, or used for racing or competition purposes. This warranty is extended to the original consumer purchaser and has a duration of 90 days from date of original purchase by such consumer. Any implied warranty determined to be applicable is limited in duration to the duration of this warranty. Some states do not allow limitations on how long an implied warranty is so the above limitation may not apply to you.

In the event of a defect in material or workmanship, **Edelbrocks** sole responsibility is to repair or replace the defective product. This warranty covers the replacement or repair at Edelbrock's option of the product only and does not cover the cost of removal or installation of the product. Final warranty determination will be the decision of **EDELBROCK**.

EDELBROCK does not warrant products which have been modified or altered outside factory specifications; subjected to conditions such as misuse, neglect, accident, improper installation or adjustment, dirt or other contaminants, weather or corrosion, gum or varnish, use of improper or poor quality fuel or fuel additives, improper fuel pressure and faulty repair or use in other than those automotive applications recommended in a current **EDELBROCK** catalog. Further, there are no warranties which extend beyond those stated here.

EDELBROCK shall not be responsible for (a) actual or alleged labor, transportation or other incidental charges or (b) actual or alleged consequential or other damages incurred by use of **EDELBROCK** *Performer Series* Carburetors. Edelbrock Corp shall not be liable for any and all consequential damages occasioned by the breach of any written or implied warranty pertaining to this sale in excess of the purchase price of the product.

Warranty claims will be initiated by returning the alleged defective product to the place of purchase with dated purchase receipt and with completed applicable **EDELBROCK** warranty claim tag. Do not send the product directly to **EDELBROCK**.

This warranty gives you specific legal rights, and you may also have other rights which vary from state to state.

The general limited Warranty supersedes all prior warranty statements. Inquiries concerning this warranty should be directed to:

EDELBROCK CORP.
2700 California St.
Torrance, CA 90503



Notes:

The Total Power Package[®] System

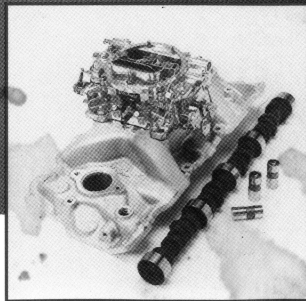

Engineered by Edelbrock for optimum performance without guesswork

The Edelbrock Performer Series carburetor is just one component of the **Edelbrock Total Power Package System** of matched components for a powerful and efficient engine. Power Packages consist of Edelbrock carburetors, intake manifolds, camshafts, and other components that have been tested together for a proven combination.

Performer Power Packages are designed to work from idle to 5500 rpm. This package is ideal for any application requiring more torque and improved driveability in the low to mid rpm range. For the high performance enthusiast,

the **Performer RPM** Total Power Package offers tremendous high-rpm horsepower while retaining torque and throttle response in the low to mid rpm range. The dual-plane intake manifold has been engineered to work with Edelbrock square-bore carburetors and high-lift Performer RPM camshafts for a broad power band of 1500-6500 rpm. **Torker II** Total Power Packages center around the Torker II manifolds which work in the 2500-6500 rpm range. Their single-plane design evolved from our famous racing manifolds, and they provide outstanding high-rpm power when the need for low-rpm torque is not so great. The low profile single-plane design also allows Torker II manifolds to be used under today's low slung hoods where high rise manifolds won't fit. Torker-Plus camshafts retain street driveability with a throaty idle.

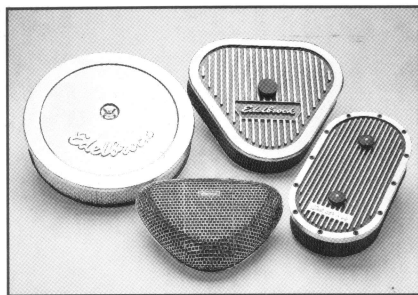

Air Cleaners and Valve Covers

Elite Series aluminum air cleaners, valve covers and breathers give a high-tech, custom look to your engine compartment. Heavy-gauge, polished aluminum is durable as well as good-looking. Raised fins are accented against a black matte background and Elite valve covers are edged with Allen-type bolts for a 2-piece look. Available with or without the distinctive Edelbrock logo. Elite air cleaners come in three shapes; round, oval and triangular. **Signature Series** chrome

air cleaners, valve covers and breathers are triple-chrome plated for a high luster finish. The Pro-Flo chrome air cleaner is available in a 14, 10 or 6 inch round shape, triangular shape, or oval for dual-quads and single 4-barrel carburetors. Our matching valve covers accept all emissions equipment, and come in tall and low profile heights. **The Pro-Flo 1000 Series** air filter is popular because it's reusable, offers excellent air flow, good filtration and a low profile. Fits all Performer Series carburetors and is simple to install.



Edelbrock Corporation
2700 California Street
Torrance, CA 90503

Tech Line: 1-800-416-8628
Hrs: 7:00-5:00 PST, Monday-Friday

Raw #63-0062
Brochure #0034